

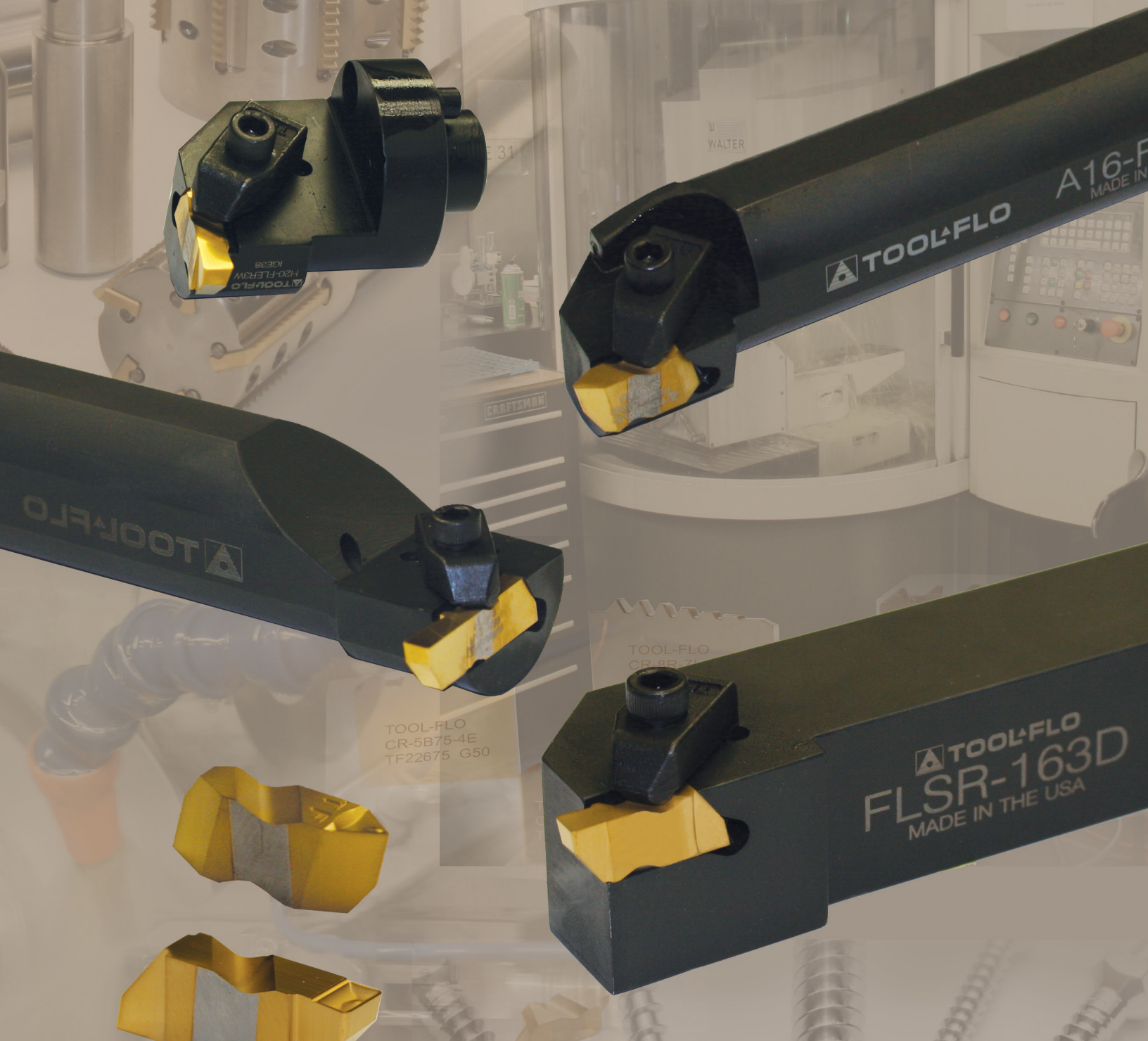

# TOOL-FLO



## FLO-LOCK

Threading & Grooving



## Flo-Lock Grooving/Threading Insert Identification Chart

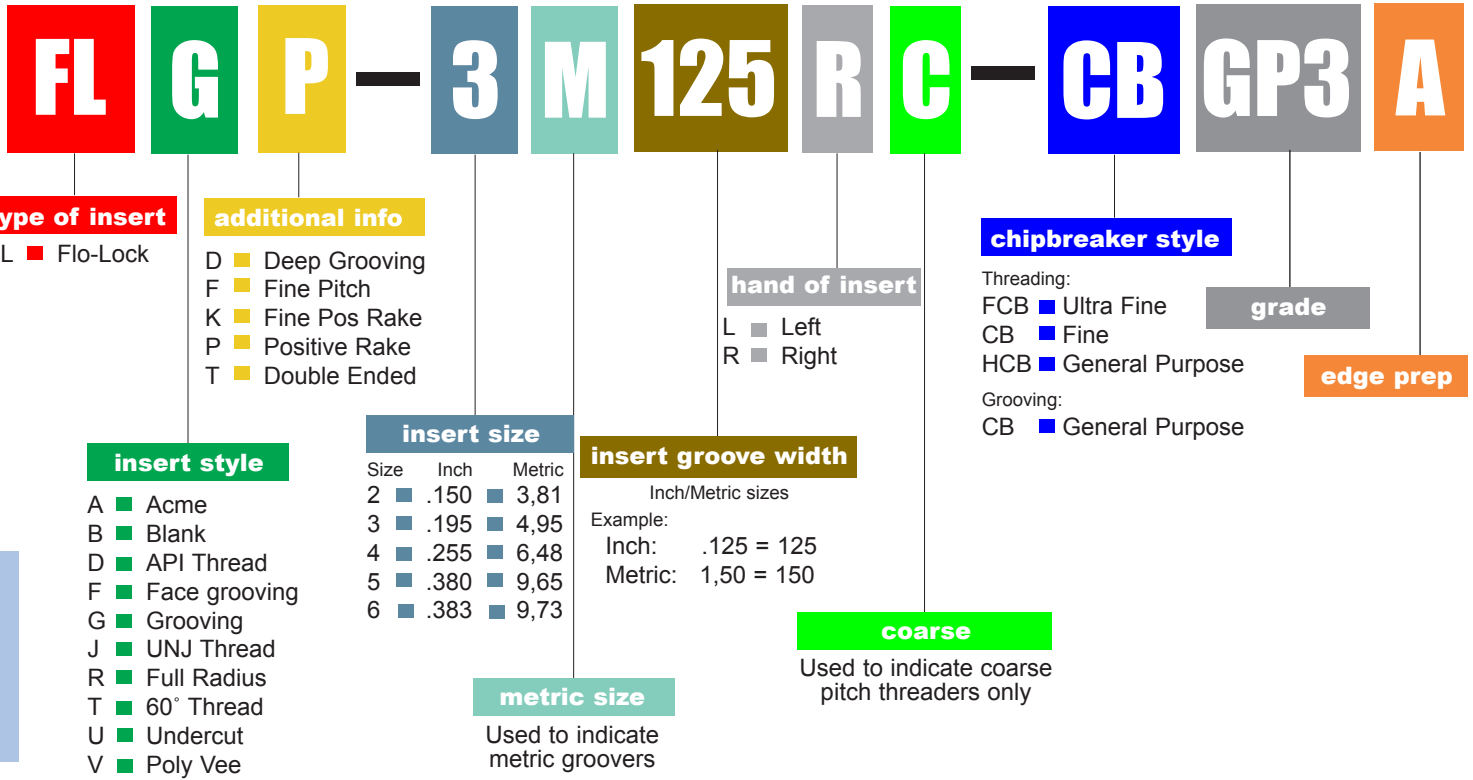

## Flo-Lock Cross Reference Chart

STYLE	TOOL-FLO	KENNAMETAL®	SANDVIK®	VALENITE®	HORIZON®	RTW®
ACME	FLA	NA	TLA	VLA	HA	PA
ACME STUBFLAS	NAS	TLAS	VLAS	HAS	PAS	
API-NON TOPPING	FLD	ND	TLD	#	#	#
API-TOPPING	FLDC	NDC	TLDC	#	HDC	PDC
DEEP GROOVING	FLGD	NGD	#	#	HGD	#
FACE GROOVING	FLF	NF	TLF	#	HF	#
GROOVING	FLG	NG	TLG	VLG	HG	PG
GROOVING-POSITIVE	FLGP	NGP	TLGP	VLGD	HGD	PGD
UNJ	FLJ	NJ	TLJ	#	HJ	#
UNJ-FINE PITCH	FLJF	NJF	TLJF	#	HJF	#
UNJ-FINE PITCH-POSITIVE	FLJK	NJK	TLJK	#	#	#
UNJ-POSITIVE	FLJP	NJP	TLJP	#	#	#
PROFILING - LH	FLPL	NPL	#	#	#	#
PROFILING - RH	FLPR	NPR	#	#	#	#
GROOVING - FNR	FLR	NR	TLR	VLR	HR	PR
GROOVING - FNR POS.	FLRP	NRP	TLRP	VLRD	HRP	PRP
60° V	FLT	NT	TLT	VLRT	HT	PT
AMERICAN STANDARD BUTTRESS	FLTB	NTB	TLTB	#	HTB	#
UN - UNIFIED	FLTC	NTC	TLTC	VLTC	HTC	PTC
60° V - FINE PITCH	FLTF	NTF	TLTF	VLTF	HTF	PTF
60° V - FINE PITCH POSITIVE	FLTK	NTK	TLTK	VLTK	HTK	PTK
60° V - POSITIVE	FLTP	NTP	TLTP	VLTP	HTP	PTP
POLY-V GROOVING	FLV	NV	TLV	#	HV	#

\*Top Clamp change is required when converting from SANDVIK®



# FLO-LOCK

## GROOVING-CHIP-FLO

### FLG-CB

w/patented chipbreaker

Exclusive patented design!

#### Features:

- Patented chipbreaker - Patent No. 6,146,064
- Maximum chip control
- Industry standard widths

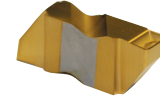
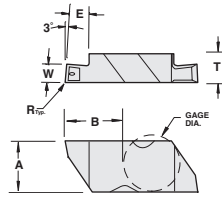

RH Shown

Description	EDP Code	W		R	E		T	A	B	Gage Dia.						
		Inch	Metric		Inch	Metric					C25	C3	GP3	GP50	AC22	AC3
FLG-2047R-CB	562647PR	.047	1.20	.002/.005	.050	1.27	.150	.219	.2700	.1875	●	●	●	●	●	●
FLG-2047L-CB	562647PL	.047	1.20	.002/.005	.050	1.27	.150	.219	.2700	.1875	●	●	●	●	●	●
FLG-2062R-CB	562662PR	.062	1.57	.005/.010	.110	2.79	.150	.219	.2700	.1875	●	●	●	●	●	●
FLG-2062L-CB	562662PL	.062	1.57	.005/.010	.110	2.79	.150	.219	.2700	.1875	●	●	●	●	●	●
FLG-2078R-CB	562678PR	.078	1.98	.005/.010	.110	2.79	.150	.219	.2700	.1875	●	●	●	●	●	●
FLG-2078L-CB	562678PL	.078	1.98	.005/.010	.110	2.79	.150	.219	.2700	.1875	●	●	●	●	●	●
FLG-2094R-CB	562694PR	.094	2.39	.005/.010	.110	2.79	.150	.219	.2700	.1875	●	●	●	●	●	●
FLG-2094L-CB	562694PL	.094	2.39	.005/.010	.110	2.79	.150	.219	.2700	.1875	●	●	●	●	●	●
FLG-2125R-CB	562825PR	.125	3.18	.005/.010	.110	2.79	.150	.219	.2700	.1875	●	●	●	●	●	●
FLG-2125L-CB	562825PL	.125	3.18	.005/.010	.110	2.79	.150	.219	.2700	.1875	●	●	●	●	●	●
FLG-3031R-CB	563631PR	.031	0.79	.002/.005	.050	1.27	.195	.344	.4050	.3750	●	●	●	●	●	●
FLG-3031L-CB	563631PL	.031	0.79	.002/.005	.050	1.27	.195	.344	.4050	.3750	●	●	●	●	●	●
FLG-3047R-CB	563647PR	.047	1.19	.005/.010	.075	1.90	.195	.344	.4050	.3750	●	●	●	●	●	●
FLG-3047L-CB	563647PL	.047	1.19	.005/.010	.075	1.90	.195	.344	.4050	.3750	●	●	●	●	●	●
FLG-3062R-CB	563662PR	.062	1.57	.005/.010	.120	3.05	.195	.344	.4050	.3750	●	●	●	●	●	●
FLG-3062L-CB	563662PL	.062	1.57	.005/.010	.120	3.05	.195	.344	.4050	.3750	●	●	●	●	●	●
FLG-3072R-CB	563672PR	.072	1.83	.005/.010	.120	3.05	.195	.344	.4050	.3750	●	●	●	●	●	●
FLG-3072L-CB	563672PL	.072	1.83	.005/.010	.120	3.05	.195	.344	.4050	.3750	●	●	●	●	●	●
FLG-3078R-CB	563678PR	.078	1.98	.005/.010	.120	3.05	.195	.344	.4050	.3750	●	●	●	●	●	●
FLG-3078L-CB	563678PL	.078	1.98	.005/.010	.120	3.05	.195	.344	.4050	.3750	●	●	●	●	●	●
FLG-3088R-CB	563688PR	.088	2.24	.005/.010	.180	4.57	.195	.344	.4050	.3750	●	●	●	●	●	●
FLG-3088L-CB	563688PL	.088	2.24	.005/.010	.180	4.57	.195	.344	.4050	.3750	●	●	●	●	●	●
FLG-3094R-CB	563694PR	.094	2.39	.005/.010	.180	4.57	.195	.344	.4050	.3750	●	●	●	●	●	●
FLG-3094L-CB	563694PL	.094	2.39	.005/.010	.180	4.57	.195	.344	.4050	.3750	●	●	●	●	●	●
FLG-3097R-CB	563697PR	.097	2.46	.005/.010	.180	4.57	.195	.344	.4050	.3750	●	●	●	●	●	●
FLG-3097L-CB	563697PL	.097	2.46	.005/.010	.180	4.57	.195	.344	.4050	.3750	●	●	●	●	●	●
FLG-3125R-CB	563825PR	.125	3.18	.005/.010	.180	4.57	.195	.344	.4050	.3750	●	●	●	●	●	●
FLG-3125L-CB	563825PL	.125	3.18	.005/.010	.180	4.57	.195	.344	.4050	.3750	●	●	●	●	●	●
FLG-3189R-CB	563889PR	.189	4.80	.020/.025	.180	4.57	.195	.344	.4050	.3750	●	●	●	●	●	●
FLG-3189L-CB	563889PL	.189	4.80	.020/.025	.180	4.57	.195	.344	.4050	.3750	●	●	●	●	●	●
FLG-4125R-CB	564825PR	.125	3.18	.005/.010	.250	6.35	.255	.453	.6360	.3750	●	●	●	●	●	●
FLG-4125L-CB	564825PL	.125	3.18	.005/.010	.250	6.35	.255	.453	.6360	.3750	●	●	●	●	●	●
FLG-4189R-CB	564889PR	.189	4.80	.020/.025	.250	6.35	.255	.453	.6360	.3750	●	●	●	●	●	●
FLG-4189L-CB	564889PL	.189	4.80	.020/.025	.250	6.35	.255	.453	.6360	.3750	●	●	●	●	●	●
FLG-4250R-CB	574050PR	.250	6.35	.020/.025	.250	6.35	.255	.453	.6360	.3750	●	●	●	●	●	●
FLG-4250L-CB	574050PL	.250	6.35	.020/.025	.250	6.35	.255	.453	.6360	.3750	●	●	●	●	●	●

In an effort to improve our stock standard grade offering, there are periodic changes.  
Please see current price list for up to date grade offering.

- High performance choice in optimal conditions.
- ▲ Recommended grade under general conditions.

Cast Iron	●	●	▲	●	●	●
Non-Ferrous	●	●	●	●	●	●
Stainless/High Temp	●	●	▲	●	●	●
Steel	●	●	●	●	▲	●

FLO-LOCK



## GROOVING-CHIP-FLO

FLG-CB - METRIC

w/patented chipbreaker

Exclusive patented design!

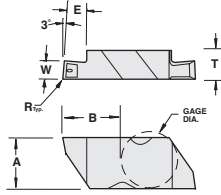

RH Shown

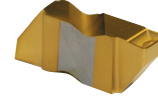

**Features:**

- Patented chipbreaker - Patent No. 6,146,064
- Maximum chip control
- Industry standard widths

FLO-LOCK

Description	EDP Code	W		R	E		T	A	B	Gage Dia.	TIN Coated		AlTiN Coated		
		Metric	Inch		GP3	GP50					AC22	AC3	AC50		
FLG-2M100R-CB	562M100PR	1,00	.039	.005/.010	1,90	.050	.150	.219	.2700	.1875	●	●	●	●	●
FLG-2M100L-CB	562M100PL	1,00	.039	.005/.010	1,90	.050	.150	.219	.270	.1875	●	●	●	●	●
FLG-2M150R-CB	562M150PR	1,50	.059	.005/.010	2,79	.110	.150	.219	.2700	.1875	●	●	●	●	●
FLG-2M150L-CB	562M150PL	1,50	.059	.005/.010	2,79	.110	.150	.219	.2700	.1875	●	●	●	●	●
FLG-2M170R-CB	562M170PR	1,70	.067	.005/.010	2,79	.110	.150	.219	.2700	.1875	●	●	●	●	●
FLG-2M170L-CB	562M170PL	1,70	.067	.005/.010	2,79	.110	.150	.219	.2700	.1875	●	●	●	●	●
FLG-2M195R-CB	562M195PR	1,95	.077	.005/.010	2,79	.110	.150	.219	.2700	.1875	●	●	●	●	●
FLG-2M195L-CB	562M195PL	1,95	.077	.005/.010	2,79	.110	.150	.219	.2700	.1875	●	●	●	●	●
FLG-2M200R-CB	562M200PR	2,00	.079	.005/.010	2,79	.110	.150	.219	.2700	.1875	●	●	●	●	●
FLG-2M200L-CB	562M200PL	2,00	.079	.005/.010	2,79	.110	.150	.219	.2700	.1875	●	●	●	●	●
FLG-2M220R-CB	562M220PR	2,20	.087	.005/.010	2,79	.110	.150	.219	.2700	.1875	●	●	●	●	●
FLG-2M220L-CB	562M220PL	2,20	.087	.005/.010	2,79	.110	.150	.219	.2700	.1875	●	●	●	●	●
FLG-2M225R-CB	562M225PR	2,25	.089	.005/.010	2,79	.110	.150	.219	.2700	.1875	●	●	●	●	●
FLG-2M225L-CB	562M225PL	2,25	.089	.005/.010	2,79	.110	.150	.219	.2700	.1875	●	●	●	●	●
FLG-2M250R-CB	562M250PR	2,50	.098	.005/.010	2,79	.110	.150	.219	.2700	.1875	●	●	●	●	●
FLG-2M250L-CB	562M250PL	2,50	.098	.005/.010	2,79	.110	.150	.219	.2700	.1875	●	●	●	●	●
FLG-2M300R-CB	562M300PR	3,00	.118	.005/.010	2,79	.110	.150	.219	.2700	.1875	●	●	●	●	●
FLG-2M300L-CB	562M300PL	3,00	.118	.005/.010	2,79	.110	.150	.219	.2700	.1875	●	●	●	●	●
FLG-2M325R-CB	562M325PR	3,25	.128	.005/.010	2,79	.110	.150	.219	.2700	.1875	●	●	●	●	●
FLG-2M325L-CB	562M325PL	3,25	.128	.005/.010	2,79	.110	.150	.219	.2700	.1875	●	●	●	●	●
FLG-3M100R-CB	563M100PR	1,00	.039	.005/.010	1,90	.050	.195	.344	.4050	.3750	●	●	●	●	●
FLG-3M100L-CB	563M100PL	1,00	.039	.005/.010	1,90	.050	.195	.344	.4050	.3750	●	●	●	●	●
FLG-3M120R-CB	563M120PR	1,20	.047	.005/.010	1,90	.075	.195	.344	.4050	.3750	●	●	●	●	●
FLG-3M120L-CB	563M120PL	1,20	.047	.005/.010	1,90	.075	.195	.344	.4050	.3750	●	●	●	●	●
FLG-3M150R-CB	563M150PR	1,50	.059	.005/.010	3,05	.120	.195	.344	.4050	.3750	●	●	●	●	●
FLG-3M150L-CB	563M150PL	1,50	.059	.005/.010	3,05	.120	.195	.344	.4050	.3750	●	●	●	●	●
FLG-3M170R-CB	563M170PR	1,70	.067	.005/.010	3,05	.120	.195	.344	.4050	.3750	●	●	●	●	●
FLG-3M170L-CB	563M170PL	1,70	.067	.005/.010	3,05	.120	.195	.344	.4050	.3750	●	●	●	●	●
FLG-3M175R-CB	563M175PR	1,75	.069	.005/.010	3,05	.120	.195	.344	.4050	.3750	●	●	●	●	●
FLG-3M175L-CB	563M175PL	1,75	.069	.005/.010	3,05	.120	.195	.344	.4050	.3750	●	●	●	●	●
FLG-3M200R-CB	563M200PR	2,00	.079	.005/.010	3,05	.120	.195	.344	.4050	.3750	●	●	●	●	●
FLG-3M200L-CB	563M200PL	2,00	.079	.005/.010	3,05	.120	.195	.344	.4050	.3750	●	●	●	●	●
FLG-3M220R-CB	563M220PR	2,20	.087	.005/.010	4,57	.180	.195	.344	.4050	.3750	●	●	●	●	●
FLG-3M220L-CB	563M220PL	2,20	.087	.005/.010	4,57	.180	.195	.344	.4050	.3750	●	●	●	●	●
FLG-3M225R-CB	563M225PR	2,25	.089	.005/.010	4,57	.180	.195	.344	.4050	.3750	●	●	●	●	●
FLG-3M225L-CB	563M225PL	2,25	.089	.005/.010	4,57	.180	.195	.344	.4050	.3750	●	●	●	●	●
FLG-3M250R-CB	563M250PR	2,50	.098	.005/.010	4,57	.180	.195	.344	.4050	.3750	●	●	●	●	●
FLG-3M250L-CB	563M250PL	2,50	.098	.005/.010	4,57	.180	.195	.344	.4050	.3750	●	●	●	●	●
FLG-3M300R-CB	563M300PR	3,00	.118	.005/.010	4,57	.180	.195	.344	.4050	.3750	●	●	●	●	●
FLG-3M300L-CB	563M300PL	3,00	.118	.005/.010	4,57	.180	.195	.344	.4050	.3750	●	●	●	●	●
FLG-3M320R-CB	563M320PR	3,20	.126	.005/.010	4,57	.180	.195	.344	.4050	.3750	●	●	●	●	●
FLG-3M320L-CB	563M320PL	3,20	.126	.005/.010	4,57	.180	.195	.344	.4050	.3750	●	●	●	●	●
FLG-3M325R-CB	563M325PR	3,25	.128	.005/.010	4,57	.180	.195	.344	.4050	.3750	●	●	●	●	●
FLG-3M325L-CB	563M325PL	3,25	.128	.005/.010	4,57	.180	.195	.344	.4050	.3750	●	●	●	●	●
FLG-3M400R-CB	563M400PR	4,00	.157	.010/.015	6,35	.180	.195	.344	.4050	.3750	●	●	●	●	●
FLG-3M400L-CB	563M400PL	4,00	.157	.010/.015	6,35	.180	.195	.344	.4050	.3750	●	●	●	●	●
FLG-4M320R-CB	564M320PR	3,20	.126	.020/.025	6,35	.250	.255	.453	.6360	.3750	●	●	●	●	●
FLG-4M320L-CB	564M320PL	3,20	.126	.020/.025	6,35	.250	.255	.453	.6360	.3750	●	●	●	●	●

In an effort to improve our stock standard grade offering, there are periodic changes. Please see current price list for up to date grade offering.

- High performance choice in optimal conditions.
- ▲ Recommended grade under general conditions.

Cast Iron	▲	●
Non-Ferrous	▲	●
Stainless/High Temp	▲	●
Steel	▲	●



# FLO-LOCK

## GROOVING FLG

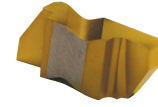
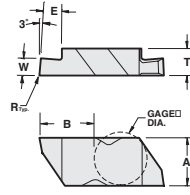

RH Shown

Description	EDP Code	W		R	E		T	A	B	Gage Dia.	Coating					
		Inch	Metric		Inch	Metric					C25	C3	GP3	GP50	AC22	AC3
FLG-2031R	562631R	.031	0,79	.002/.005	.050	1,27	.150	.219	.2700	.1875	●	●	●	●	●	●
FLG-2031L	562631L	.031	0,79	.002/.005	.050	1,27	.150	.219	.2700	.1875	●	●	●	●	●	●
FLG-2041R	562641R	.041	1,04	.002/.005	.050	1,27	.150	.219	.2700	.1875	●	●	●	●	●	●
FLG-2041L	562641L	.041	1,04	.002/.005	.050	1,27	.150	.219	.2700	.1875	●	●	●	●	●	●
FLG-2047R	562647R	.047	1,19	.002/.005	.050	1,27	.150	.219	.2700	.1875	●	●	●	●	●	●
FLG-2047L	562647L	.047	1,19	.002/.005	.050	1,27	.150	.219	.2700	.1875	●	●	●	●	●	●
FLG-2058R	562658R	.058	1,47	.005/.010	.050	1,27	.150	.219	.2700	.1875	●	●	●	●	●	●
FLG-2058L	562658L	.058	1,47	.005/.010	.050	1,27	.150	.219	.2700	.1875	●	●	●	●	●	●
FLG-2062R	562662R	.062	1,57	.005/.010	.110	2,79	.150	.219	.2700	.1875	●	●	●	●	●	●
FLG-2062L	562662L	.062	1,57	.005/.010	.110	2,79	.150	.219	.2700	.1875	●	●	●	●	●	●
FLG-2094R	562694R	.094	2,39	.005/.010	.110	2,79	.150	.219	.2700	.1875	●	●	●	●	●	●
FLG-2094L	562694L	.094	2,39	.005/.010	.110	2,79	.150	.219	.2700	.1875	●	●	●	●	●	●
FLG-2125R	562825R	.125	3,18	.005/.010	.110	2,79	.150	.219	.2700	.1875	●	●	●	●	●	●
FLG-2125L	562825L	.125	3,18	.005/.010	.110	2,79	.150	.219	.2700	.1875	●	●	●	●	●	●
FLG-3031R	563631R	.031	0,79	.002/.005	.050	1,27	.195	.344	.4050	.3750	●	●	●	●	●	●
FLG-3031L	563631L	.031	0,79	.002/.005	.050	1,27	.195	.344	.4050	.3750	●	●	●	●	●	●
FLG-3047R	563647R	.047	1,19	.005/.010	.075	1,90	.195	.344	.4050	.3750	●	●	●	●	●	●
FLG-3047L	563647L	.047	1,19	.005/.010	.075	1,90	.195	.344	.4050	.3750	●	●	●	●	●	●
FLG-3062R	563662R	.062	1,57	.005/.010	.120	3,05	.195	.344	.4050	.3750	●	●	●	●	●	●
FLG-3062L	563662L	.062	1,57	.005/.010	.120	3,05	.195	.344	.4050	.3750	●	●	●	●	●	●
FLG-3072R	563672R	.072	1,83	.005/.010	.120	3,05	.195	.344	.4050	.3750	●	●	●	●	●	●
FLG-3072L	563672L	.072	1,83	.005/.010	.120	3,05	.195	.344	.4050	.3750	●	●	●	●	●	●
FLG-3078R	563678R	.078	1,98	.005/.010	.120	3,05	.195	.344	.4050	.3750	●	●	●	●	●	●
FLG-3078L	563678L	.078	1,98	.005/.010	.120	3,05	.195	.344	.4050	.3750	●	●	●	●	●	●
FLG-3088R	563688R	.088	2,24	.005/.010	.180	4,57	.195	.344	.4050	.3750	●	●	●	●	●	●
FLG-3088L	563688L	.088	2,24	.005/.010	.180	4,57	.195	.344	.4050	.3750	●	●	●	●	●	●
FLG-3094R	563694R	.094	2,39	.005/.010	.180	4,57	.195	.344	.4050	.3750	●	●	●	●	●	●
FLG-3094L	563694L	.094	2,39	.005/.010	.180	4,57	.195	.344	.4050	.3750	●	●	●	●	●	●
FLG-3097R	563697R	.097	2,46	.010/.015	.180	4,57	.195	.344	.4050	.3750	●	●	●	●	●	●
FLG-3097L	563697L	.097	2,46	.010/.015	.180	4,57	.195	.344	.4050	.3750	●	●	●	●	●	●
FLG-3105R	563805R	.105	2,67	.005/.010	.180	4,57	.195	.344	.4050	.3750	●	●	●	●	●	●
FLG-3105L	563805L	.105	2,67	.005/.010	.180	4,57	.195	.344	.4050	.3750	●	●	●	●	●	●
FLG-3110R	563810R	.110	2,79	.005/.010	.180	4,57	.195	.344	.4050	.3750	●	●	●	●	●	●
FLG-3110L	563810L	.110	2,79	.005/.010	.180	4,57	.195	.344	.4050	.3750	●	●	●	●	●	●
FLG-3122R	563822R	.122	3,10	.005/.010	.180	4,57	.195	.344	.4050	.3750	●	●	●	●	●	●
FLG-3122L	563822L	.122	3,10	.005/.010	.180	4,57	.195	.344	.4050	.3750	●	●	●	●	●	●
FLG-3125R	563825R	.125	3,18	.005/.010	.180	4,57	.195	.344	.4050	.3750	●	●	●	●	●	●
FLG-3125L	563825L	.125	3,18	.005/.010	.180	4,57	.195	.344	.4050	.3750	●	●	●	●	●	●
FLG-3142R	563842R	.142	3,61	.005/.010	.180	4,57	.195	.344	.4050	.3750	●	●	●	●	●	●
FLG-3142L	563842L	.142	3,61	.005/.010	.180	4,57	.195	.344	.4050	.3750	●	●	●	●	●	●
FLG-3156R	563856R	.156	3,96	.005/.010	.180	4,57	.195	.344	.4050	.3750	●	●	●	●	●	●
FLG-3156L	563856L	.156	3,96	.005/.010	.180	4,57	.195	.344	.4050	.3750	●	●	●	●	●	●
FLG-3178R	563878R	.178	4,52	.005/.010	.180	4,57	.195	.344	.4050	.3750	●	●	●	●	●	●
FLG-3178L	563878L	.178	4,52	.005/.010	.180	4,57	.195	.344	.4050	.3750	●	●	●	●	●	●
FLG-3185R	563885R	.185	4,70	.020/.025	.180	4,57	.195	.344	.4050	.3750	●	●	●	●	●	●
FLG-3185L	563885L	.185	4,70	.020/.025	.180	4,57	.195	.344	.4050	.3750	●	●	●	●	●	●
FLG-3189R	563889R	.189	4,80	.020/.025	.180	4,57	.195	.344	.4050	.3750	●	●	●	●	●	●
FLG-3189L	563889L	.189	4,80	.020/.025	.180	4,57	.195	.344	.4050	.3750	●	●	●	●	●	●
FLG-3250R	573050R	.250	6,35	.020/.025	.180	4,57	.250	.344	.4050	.3750	●	●	●	●	●	●
FLG-3250L	573050L	.250	6,35	.020/.025	.180	4,57	.250	.344	.4050	.3750	●	●	●	●	●	●

In an effort to improve our stock standard grade offering, there are periodic changes. Please see current price list for up to date grade offering.

- High performance choice in optimal conditions.
- ▲ Recommended grade under general conditions.

Cast Iron	●	▲	●	●	●	●
Non-Ferrous	●	▲	●	●	●	●
Stainless/High Temp	●	▲	●	●	●	●
Steel	●	▲	●	●	●	●

FLO-LOCK







## FACE GROOVING - CHIP-FLO

FLF-CB

Exclusive patented design!

**Features:**

- Patented chipbreaker - Patent No. 6,146,064
- Maximum chip control
- Industry standard widths

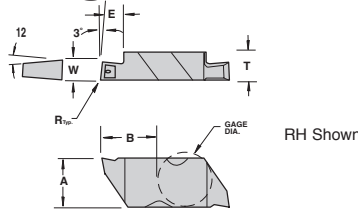

Description	EDP Code	Inch	Metric	R	E	T	A	B	Dia.	Gage				
										C3	GP3	GP50	AC3	AC50
FLF-3125R-CB	563025PR	.125	3,18	.005/.010	.180	.195	.344	.4050	.3750	●	●	●	●	●
FLF-3125L-CB	563025PL	.125	3,18	.005/.010	.180	.195	.344	.4050	.3750	●	●	●	●	●
FLF-3156R-CB	563056PR	.156	3,96	.005/.010	.180	.195	.344	.4050	.3750	●	●	●	●	●
FLF-3156L-CB	563056PL	.156	3,96	.005/.010	.180	.195	.344	.4050	.3750	●	●	●	●	●
FLF-3188R-CB	563088PR	.188	4,77	.020/.025	.180	.195	.344	.4050	.3750	●	●	●	●	●
FLF-3188L-CB	563088PL	.188	4,77	.020/.025	.180	.195	.344	.4050	.3750	●	●	●	●	●

## FACE GROOVING

FLF

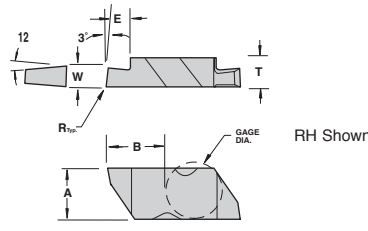

Description	EDP Code	Inch	Metric	R	E	T	A	B	Dia.	Gage				
										C3	GP3	GP50	AC3	AC50
FLF-3125R	563025R	.125	3,18	.005/.010	.180	.195	.344	.4050	.3750	●	●	●	●	●
FLF-3125L	563025L	.125	3,18	.005/.010	.180	.195	.344	.4050	.3750	●	●	●	●	●
FLF-3156R	563056R	.156	3,96	.005/.010	.180	.195	.344	.4050	.3750	●	●	●	●	●
FLF-3156L	563025L	.156	3,96	.005/.010	.180	.195	.344	.4050	.3750	●	●	●	●	●
FLF-3188R	563088R	.188	4,77	.020/.025	.180	.195	.344	.4050	.3750	●	●	●	●	●
FLF-3188L	563088L	.188	4,77	.020/.025	.180	.195	.344	.4050	.3750	●	●	●	●	●
FLF-4250R	564250R	.250	6,35	.020/.025	.250	.255	.453	.6360	.3750	●	●	●	●	●
FLF-4250L	564250L	.250	6,35	.020/.025	.250	.255	.453	.6360	.3750	●	●	●	●	●
FLF-6218R	566218R	.218	5,54	.030/.035	.250	.383	.453	.6360	.3750	●	●	●	●	●
FLF-6218L	566218L	.218	5,54	.030/.035	.250	.383	.453	.6360	.3750	●	●	●	●	●
FLF-6250R	566250R	.250	6,35	.030/.035	.250	.383	.453	.6360	.3750	●	●	●	●	●
FLF-6250L	566250L	.250	6,35	.030/.035	.250	.383	.453	.6360	.3750	●	●	●	●	●
FLF-6375R	566475R	.375	9,53	.030/.035	.250	.383	.453	.6360	.3750	●	●	●	●	●
FLF-6375L	566475L	.375	9,53	.030/.035	.250	.383	.453	.6360	.3750	●	●	●	●	●

## DEEP GROOVING - CHIP-FLO

FLGD-CB

Single ended

Exclusive patented design!

**Features:**

- Patented chipbreaker - Patent No. 6,146,064
- Maximum chip control
- Industry standard widths

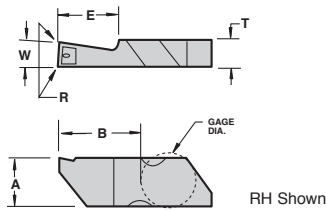

Description	EDP Code	Inch	Metric	R	E	T	A	B	Dia.	Gage				
										C3	GP3	GP50	AC3	AC50
FLGD-3062R-CB (FLG-3062R-CB)*	563662PR	.062	1,57	.005/.010	.120	.195	.344	.5050	.3750	●	●	●	●	●
FLGD-3062L-CB (FLG-3062L-CB)*	563662PL	.062	1,57	.005/.010	.120	.195	.344	.5050	.3750	●	●	●	●	●
FLGD-3094R-CB	6335094PR	.094	2,39	.005/.010	.250	.195	.344	.5050	.3750	●	●	●	●	●
FLGD-3094L-CB	6335094PL	.094	2,39	.005/.010	.250	.195	.344	.5050	.3750	●	●	●	●	●
FLGD-3125R-CB	6335125PR	.125	3,18	.005/.010	.250	.195	.344	.5050	.3750	●	●	●	●	●
FLGD-3125L-CB	6335125PL	.125	3,18	.005/.010	.250	.195	.344	.5050	.3750	●	●	●	●	●
FLGD-3189R-CB	6335189PR	.189	4,80	.020/.025	.250	.195	.344	.5050	.3750	●	●	●	●	●
FLGD-3189L-CB	6335189PL	.189	4,80	.020/.025	.250	.195	.344	.5050	.3750	●	●	●	●	●
FLGD-4189R-CB	6345189PR	.189	4,80	.020/.025	.375	.255	.453	.7610	.3750	●	●	●	●	●
FLGD-4189L-CB	6345189PL	.189	4,80	.020/.025	.375	.255	.453	.7610	.3750	●	●	●	●	●
FLGD-4250R-CB	6345250PR	.250	6,35	.020/.025	.500	.255	.453	.8860	.3750	●	●	●	●	●
FLGD-4250L-CB	6345250PL	.250	6,35	.020/.025	.500	.255	.453	.8860	.3750	●	●	●	●	●

\*Inserts are double ended.

In an effort to improve our stock standard grade offering, there are periodic changes. Please see current price list for up to date grade offering.

- High performance choice in optimal conditions.
- ▲ Recommended grade under general conditions.

	Uncoated	TIN Coated	AlTiN Coated
Cast Iron	▲	●	●
Non-Ferrous	▲	●	●
Stainless/High Temp	▲	●	●
Steel	▲	●	●





# FLO-LOCK

## DEEP GROOVING

FLGD

Single ended

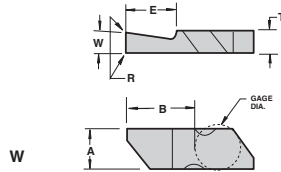

RH Shown

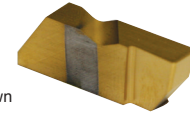

Description	EDP Code	Inch	Metric	R	E	T	A	B	Dia.	Gage				
										C3	GP3	GP50	AC3	AC50
FLGD-3062R (FLG-3062R)*	563662R	.062	1,57	.005/.010	.120	.195	.344	.5050	.3750	●	●	●	●	●
FLGD-3062L (FLG-3062L)*	563662L	.062	1,57	.005/.010	.120	.195	.344	.5050	.3750	●	●	●	●	●
FLGD-3094R	6334094R	.094	2,39	.005/.010	.250	.195	.344	.5050	.3750	●	●	●	●	●
FLGD-3094L	6334094L	.094	2,39	.005/.010	.250	.195	.344	.5050	.3750	●	●	●	●	●
FLGD-3125R	6334125R	.125	3,18	.005/.010	.250	.195	.344	.5050	.3750	●	●	●	●	●
FLGD-3125L	6334125L	.125	3,18	.005/.010	.250	.195	.344	.5050	.3750	●	●	●	●	●
FLGD-3189R	6334189R	.189	4,8	.020/.025	.250	.195	.344	.5050	.3750	●	●	●	●	●
FLGD-3189L	6334189L	.189	4,8	.020/.025	.250	.195	.344	.5050	.3750	●	●	●	●	●
FLGD-4125R (FLG-4125R)*	564825R	.125	3,18	.005/.010	.250	.255	.453	.6360	.3750	●	●	●	●	●
FLGD-4125L (FLG-4125L)*	564825L	.125	3,18	.005/.010	.250	.255	.453	.6360	.3750	●	●	●	●	●
FLGD-4189R	6344189R	.189	4,8	.020/.025	.375	.255	.453	.7610	.3750	●	●	●	●	●
FLGD-4189L	6344189L	.189	4,8	.020/.025	.375	.255	.453	.7610	.3750	●	●	●	●	●
FLGD-4250R	6344250R	.250	6,35	.020/.025	.500	.255	.453	.8860	.3750	●	●	●	●	●
FLGD-4250L	6344250L	.250	6,35	.020/.025	.500	.255	.453	.8860	.3750	●	●	●	●	●

\*Inserts are double ended.

## DEEP GROOVING - FNR

FLRD

Full nose radius - Single ended

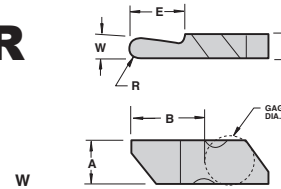

RH Shown

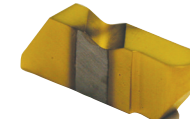

Description	EDP Code	Inch	Metric	R	E	T	A	B	Dia.	Gage				
										C3	GP3	GP50	AC3	AC50
FLRD-3031R (FLR-3031R)*	593031R	.062	1,57	.031	.125	.195	.344	.5016	.3750	●	●	●	●	●
FLRD-3031L (FLR-3031L)*	593031L	.062	1,57	.031	.125	.195	.344	.5016	.3750	●	●	●	●	●
FLRD-3062R	6336062R	.125	3,19	.062	.250	.195	.344	.5016	.3750	●	●	●	●	●
FLRD-3062L	6336062L	.125	3,19	.062	.250	.195	.344	.5016	.3750	●	●	●	●	●
FLRD-3094R	6336094R	.189	4,8	.094	.250	.195	.344	.5016	.3750	●	●	●	●	●
FLRD-3094L	6336094L	.189	4,8	.094	.250	.195	.344	.5016	.3750	●	●	●	●	●
FLRD-4094R	6346094R	.189	4,8	.094	.500	.255	.453	.8860	.3750	●	●	●	●	●
FLRD-4094L	6346094L	.189	4,8	.094	.500	.255	.453	.8860	.3750	●	●	●	●	●
FLRD-4125R	6346125R	.250	6,35	.125	.500	.255	.453	.8860	.3750	●	●	●	●	●
FLRD-4125L	6346125L	.250	6,35	.125	.500	.255	.453	.8860	.3750	●	●	●	●	●

\*Inserts are double ended.

## INTERNAL DEEP FACE GROOVING - CHIP-FLO

FLFD-I-CB

Single ended

Exclusive patented design!

Features:

- Patented chipbreaker  
Patent No. 6,146,064
- Maximum chip control
- Industry standard widths w

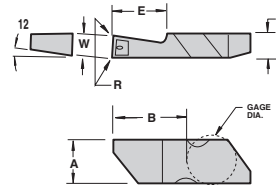

RH Shown

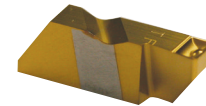

Description	EDP Code	Inch	Metric	R	E	T	A	B	Dia.	Gage				
										C3	GP3	GP50	AC3	AC50
FLFD-3125R-I-CB	6338125PRI	.125	3,18	.005/.010	.250	.195	.344	.5050	.3750	●	●	●	●	●
FLFD-3125L-I-CB	6338125PLI	.125	3,18	.005/.010	.250	.195	.344	.5050	.3750	●	●	●	●	●
FLFD-3189R-I-CB	6338189PRI	.189	4,80	.020/.025	.250	.195	.344	.5050	.3750	●	●	●	●	●
FLFD-3189L-I-CB	6338189PLI	.189	4,80	.020/.025	.250	.195	.344	.5050	.3750	●	●	●	●	●

## DEEP FACE GROOVING CHIP-FLO

FLFD-CB

Single ended

Exclusive patented design!

Features:

- Patented chipbreaker  
Patent No. 6,146,064
- Maximum chip control
- Industry standard widths w

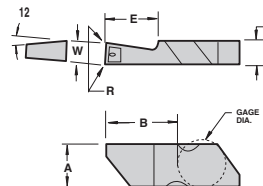

RH Shown

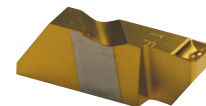

Description	EDP Code	Inch	Metric	R	E	T	A	B	Dia.	Gage				
										C3	GP3	GP50	AC3	AC50
FLFD-3125R-CB	6338125PR	.125	3,18	.005/.010	.250	.195	.344	.5050	.3750	●	●	●	●	●
FLFD-3125L-CB	6338125PL	.125	3,18	.005/.010	.250	.195	.344	.5050	.3750	●	●	●	●	●
FLFD-3189R-CB	6338189PR	.189	4,80	.020/.025	.250	.195	.344	.5050	.3750	●	●	●	●	●
FLFD-3189L-CB	6338189PL	.189	4,80	.020/.025	.250	.195	.344	.5050	.3750	●	●	●	●	●

In an effort to improve our stock standard grade offering, there are periodic changes. Please see current price list for up to date grade offering.

- High performance choice in optimal conditions.
- ▲ Recommended grade under general conditions.

Cast Iron	Non-Ferrous	Stainless/High Temp	Steel
▲	●	●	●
▲	●	●	●
▲	●	●	●
▲	●	●	●



## DEEP GROOVING

### FLGT

Double ended

*Exclusive 2 edge design!*

Fits FLSLT/RT Holders. See page 110

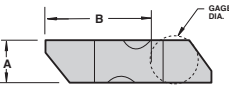
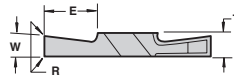

RH Shown



Description	EDP Code	Inch	Metric	R	E	T	A	B	Dia.	Gage				
										C3	GP3	GP50	AC3	AC50
FLGT-3094R	6332094R	.094	2,39	.005/.010	.275	.195	.344	.855	.3750					
FLGT-3094L	6332094L	.094	2,39	.005/.010	.275	.195	.344	.855	.3750					
FLGT-3125R	6332125R	.125	3,18	.005/.010	.437	.195	.344	.855	.3750					
FLGT-3125L	6332125L	.125	3,18	.005/.010	.437	.195	.344	.855	.3750					
FLGT-3189R	6332189R	.189	4,8	.020/.025	.437	.195	.344	.855	.3750					
FLGT-3189L	6332189L	.189	4,8	.020/.025	.437	.195	.344	.855	.3750					
FLGT-4125R	6342125R	.125	3,18	.005/.010	.550	.255	.453	1.136	.3750					
FLGT-4125L	6342125L	.125	3,18	.005/.010	.550	.255	.453	1.136	.3750					
FLGT-4189R	6342189R	.189	4,8	.020/.025	.550	.255	.453	1.136	.3750					
FLGT-4189L	6342189L	.189	4,8	.020/.025	.550	.255	.453	1.136	.3750					
FLGT-4250R	6342250R	.250	6,35	.020/.025	.550	.255	.453	1.136	.3750					
FLGT-4250L	6342250L	.250	6,35	.020/.025	.550	.255	.453	1.136	.3750					

## DEEP FACE GROOVING

### FLFT

Double ended

*Exclusive 2 edge design!*

Fits FLSLT/RT Holders. See page 110

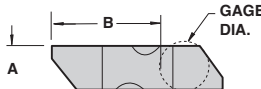
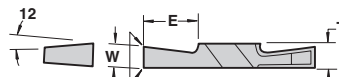

RH Shown



Description	EDP Code	Inch	Metric	R	E	T	A	B	Dia.	Gage				
										C3	GP3	GP50	AC3	AC50
FLFT-3125R	6339125R	.125	3,18	.005/.010	.375	.195	.344	.885	.3750					
FLFT-3125L	6339125L	.125	3,18	.005/.010	.375	.195	.344	.885	.3750					
FLFT-4189R	6349189R	.189	4,8	.020/.025	.550	.255	.453	1.136	.3750					
FLFT-4189L	6349189L	.189	4,8	.020/.025	.550	.255	.453	1.136	.3750					
FLFT-4250R	6349250R	.250	6,35	.020/.025	.550	.255	.453	1.136	.3750					
FLFT-4250L	6349250L	.250	6,35	.020/.025	.550	.255	.453	1.136	.3750					

## DEEP GROOVING - FNR

### FLRT

Double ended

*Exclusive 2 edge design!*

Fits FLSLT/RT Holders. See page 110

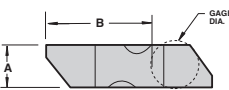
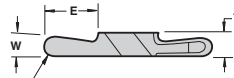

RH Shown

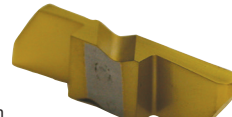

Description	EDP Code	Inch	Metric	R	E	T	A	B	Dia.	Gage				
										C3	GP3	GP50	AC3	AC50
FLRT-3062R	6337062R	.125	3,18	.062	.437	.195	.344	.855	.3750					
FLRT-3062L	6337062L	.125	3,18	.062	.437	.195	.344	.855	.3750					
FLRT-3094R	6337094R	.189	4,80	.094	.437	.195	.344	.855	.3750					
FLRT-3094L	6337094L	.189	4,80	.094	.437	.195	.344	.855	.3750					
FLRT-4062R	6347062R	.125	3,18	.062	.550	.255	.453	1.136	.3750					
FLRT-4062L	6347062L	.125	3,18	.062	.550	.255	.453	1.136	.3750					
FLRT-4094R	6347094R	.189	4,8	.094	.550	.255	.453	1.136	.3750					
FLRT-4094L	6347094L	.189	4,8	.094	.550	.255	.453	1.136	.3750					
FLRT-4125R	6347125R	.250	6,35	.125	.550	.255	.453	1.136	.3750					
FLRT-4125L	6347125L	.250	6,35	.125	.550	.255	.453	1.136	.3750					

In an effort to improve our stock standard grade offering, there are periodic changes. Please see current price list for up to date grade offering.

- High performance choice in optimal conditions.
- ▲ Recommended grade under general conditions.

	Uncoated	TIN Coated	AlTIN Coated
Cast Iron		▲	●
Non-Ferrous		▲	●
Stainless/High Temp		▲	●
Steel		▲	●



# FLO-LOCK

## Recommended Feed rate - inch/rev (mm/rev)

Workpiece Group	Insert Rake Configuration	
	FLG-Neutral	FLG-CB
Free Machining Carbon Steels	.004-.010	.005-.014
Plain Carbon Steels	.004-.010	.005-.014
Alloy Steels 190-330 HB	.004-.010	.005-.014
Alloy Steels 330-450 HB	.003-.009	.005-.012
Martensitic/Ferritic Stainless Steel 400 Series	.004-.010	.005-.014
Austenitic Stainless 300 Series	.003-.006	.004-.008
Gray Cast Iron 190-330 HB	.004-.010	---
Gray Cast Iron 330-450 HB	.003-.009	---
Alloy / Ductile Irons	.004-.010	.005-.014
Free Machining Aluminum Alloys	.005-.012	.006-.016
High-Silicon Aluminum Alloys	.003-.006	---
Copper / Zinc / Brass	.005-.012	.006-.016
Non-Metallics	.005-.012	---
High Temperature Alloys 200-260 HB	.003-.006	.004-.007
High Temperature Alloys 260-450 HB	.003-.006	.004-.007
Titanium Alloys (Ti 6Al-4V)	.003-.006	.004-.008
Hardened Materials 48-65 HRC	.0015-.005	---

## Flo-Lock Series Kits



### THREADING KITS

#### V-THREADING KIT #1A

1	FLSR-163D
4	FLT-3R-HCB GP50
1	S-412 SCREW

#### V-THREADING KIT #1B

1	FLSR-163D
4	FLT-3R-HCB GP3
1	S-412 SCREW

### GROOVING KITS

#### W.125 GROOVING KIT #2A

1	FLSR-163D
4	FLG-3125R-CB GP50
1	S-412 SCREW

#### W.125 GROOVING KIT #2B

1	FLSR-163D
4	FLG-3125R-CB GP3
1	S-412 SCREW

#### W.094 GROOVING KIT #3A

1	FLSR-163D
4	FLG-3094R-CB GP50
1	S-412 SCREW

#### W.094 GROOVING KIT #3B

1	FLSR-163D
4	FLG-3094R-CB GP3
1	S-412 SCREW

#### W.062 GROOVING KIT #4A

1	FLSR-163D
4	FLG-3062R-CB GP50
1	S-412 SCREW

#### W.062 GROOVING KIT #4B

1	FLSR-163D
4	FLG-3062R-CB GP3
1	S-412 SCREW

#### W.047 GROOVING KIT #5A

1	FLSR-163D
4	FLG-3047R-CB GP50
1	S-412 SCREW

#### W.047 GROOVING KIT #5B

1	FLSR-163D
4	FLG-3047R-CB GP3
1	S-412 SCREW

### DEEP GROOVING KITS

#### W.125 GROOVING KIT #6

1	FLSR-163D
4	FLGD-3125R-CB AC3
1	S-412 SCREW

#### W.094 GROOVING KIT #7

1	FLSR-163D
4	FLGD-3094R-CB AC3
1	S-412 SCREW



FLO-LOCK

## Recommended SFM for Grooving Applications

Workpiece Group	Uncoated	TiN PVD Coated				AlTiN PVD Coated			TiN Cermet	CBN		PCD
	C3	GP22	GP3	GP4	GP50	AC22	AC3	AC50	GPM6	CB200	CB400	PC33
Free Machining Carbon Steels	---	150-300	200-400	60-175	<b>200-600</b>	200-400	250-450	<b>400-800</b>	<b>600-1500</b>	---	---	---
Plain Carbon Steels	---	150-300	200-400	60-175	<b>200-600</b>	200-400	250-450	<b>450-800</b>	<b>600-1200</b>	---	---	---
Alloy Steels 190-330 HB	---	150-300	200-400	60-150	<b>200-500</b>	200-350	250-400	<b>400-800</b>	<b>500-1100</b>	---	---	---
Alloy Steels 330-450 HB	---	150-300	200-350	60-150	<b>200-450</b>	200-350	250-400	<b>400-750</b>	<b>600-800</b>	---	---	---
Martensitic/Ferritic Stainless Steel 400 Series	---	150-300	200-400	60-150	<b>200-500</b>	200-400	250-450	<b>350-700</b>	<b>500-800</b>	---	---	---
Austenitic Stainless 300 Series	200-400	150-400	<b>200-500</b>	60-150	---	300-600	<b>250-700</b>	---	<b>500-1000</b>	---	---	---
Gray Cast Iron 190-330 HB	100-375	150-400	<b>200-600</b>	60-150	---	300-600	<b>250-700</b>	---	<b>400-1100</b>	<b>1400-2500</b>	---	---
Gray Cast Iron 330-450 HB	100-350	150-350	<b>200-500</b>	60-150	---	200-550	<b>250-600</b>	---	<b>350-950</b>	<b>1200-1800</b>	---	---
Alloy / Ductile Irons	100-350	150-300	200-400	60-150	<b>200-500</b>	250-450	200-450	<b>300-700</b>	<b>350-950</b>	---	---	---
Free Machining Aluminum Alloys	500-2000	150-2000	<b>300-2000</b>	60-150	---	600-2200	<b>600-2500</b>	---	---	---	---	<b>1000-8000</b>
High-Silicon Aluminum Alloys	---	---	---	---	---	---	---	---	---	---	---	<b>1000-5000</b>
Copper / Zinc / Brass	200-700	150-700	<b>200-900</b>	---	---	300-900	<b>400-1000</b>	---	---	---	---	<b>1000-4000</b>
Non-Metallics	400-1400	150-1500	<b>300-1500</b>	---	---	350-1200	400-1500	---	---	---	---	<b>1000-4500</b>
High Temperature Alloys 200-260 HB	80-130	100-175	100-200	50-80	---	80-200	100-250	---	---	<b>300-600</b>	---	---
High Temperature Alloys 260-450 HB	50-100	80-150	100-175	50-80	---	80-175	<b>100-200</b>	---	---	<b>250-450</b>	---	---
Titanium Alloys (Ti 6Al-4V)	100-200	100-250	150-300	50-80	---	80-300	<b>100-300</b>	---	---	---	---	---
Hardened Materials 48-65 HRC	---	---	---	---	---	---	<b>80-150</b>	---	---	<b>150-350</b>	<b>200-550</b>	---

Bold print items denote the top choices for the materials listed, provided it can be machined within the SFM stated under the appropriate machining conditions. For the best performance in optimal machining conditions, select the grade that will provide you with the highest allowable SFM.



## ACME THREADING FLA

For Flo-Lock acme thread limits see pg. 111,112.

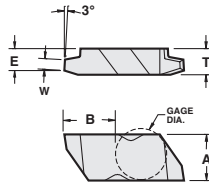

RH Shown

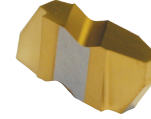

Description	EDP Code	TPI	W	T	E	A	B	Gage Dia.	Coating					
									C3	GP3	GP50	AC3	AC50	
FLA-3R16	553016R	16	.0206	.195	.149	.344	.4026	.3750						
FLA-3L16	553016L	16	.0206	.195	.149	.344	.4026	.3750						
FLA-3R14	553014R	14	.0239	.195	.149	.344	.4026	.3750						
FLA-3L14	553014L	14	.0239	.195	.149	.344	.4026	.3750						
FLA-3R12	553012R	12	.0283	.195	.149	.344	.4026	.3750						
FLA-3L12	553012L	12	.0283	.195	.149	.344	.4026	.3750						
FLA-3R10	553010R	10	.0319	.195	.149	.344	.4026	.3750						
FLA-3L10	553010L	10	.0319	.195	.149	.344	.4026	.3750						
FLA-3R8	553008R	8	.0411	.195	.149	.344	.4026	.3750						
FLA-3L8	553008L	8	.0411	.195	.149	.344	.4026	.3750						
FLA-3R6	553006R	6	.0566	.195	.149	.344	.4026	.3750						
FLA-3L6	553006L	6	.0566	.195	.149	.344	.4026	.3750						
FLA-3R5	553005R	5	.0689	.195	.149	.344	.4026	.3750						
FLA-3L5	553005L	5	.0689	.195	.149	.344	.4026	.3750						
FLA-3R4	553004R	4	.0875	.195	.133	.344	.4018	.3750						
FLA-3L4	553004L	4	.0875	.195	.133	.344	.4018	.3750						
FLA-4R8	554008R	8	.0411	.255	.202	.453	.6332	.3750						
FLA-4L8	554008L	8	.0411	.255	.202	.453	.6332	.3750						
FLA-4R6	554006R	6	.0566	.255	.202	.453	.6332	.3750						
FLA-4L6	554006L	6	.0566	.255	.202	.453	.6332	.3750						
FLA-4R5	554005R	5	.0689	.255	.202	.453	.6332	.3750						
FLA-4L5	554005L	5	.0689	.255	.202	.453	.6332	.3750						
FLA-4R4	554004R	4	.0875	.255	.202	.453	.6332	.3750						
FLA-4L4	554004L	4	.0875	.255	.202	.453	.6332	.3750						
FLA-6R3	556003R	3	.1184	.383	.283	.453	.6308	.3750						
FLA-6L3	556003L	3	.1184	.383	.283	.453	.6308	.3750						
FLA-6R2.5	5560025R	2.5	.1431	.383	.283	.453	.6308	.3750						
FLA-6L2.5	5560025L	2.5	.1431	.383	.283	.453	.6308	.3750						
FLA-6R2	556002R	2	.1802	.383	.283	.453	.6308	.3750						
FLA-6L2	556002L	2	.1802	.383	.283	.453	.6308	.3750						

FLO-LOCK

## ACME STUB THREADING FLAS

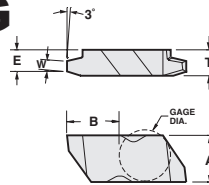

RH Shown

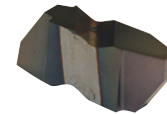

Description	EDP Code	TPI	W	T	E	A	B	Gage Dia.	Coating					
									C3	GP3	GP50	AC3	AC50	
FLAS-3R16	553216R	16	.0238	.195	.149	.344	.4026	.375						
FLAS-3L16	553216L	16	.0238	.195	.149	.344	.4026	.375						
FLAS-3R14	553214R	14	.0276	.195	.149	.344	.4026	.375						
FLAS-3L14	553214L	14	.0276	.195	.149	.344	.4026	.375						
FLAS-3R12	553212R	12	.0326	.195	.149	.344	.4026	.375						
FLAS-3L12	553212L	12	.0326	.195	.149	.344	.4026	.375						
FLAS-3R10	553210R	10	.0370	.195	.149	.344	.4026	.375						
FLAS-3L10	553210L	10	.0370	.195	.149	.344	.4026	.375						
FLAS-3R8	553208R	8	.0476	.195	.149	.344	.4026	.375						
FLAS-3L8	553208L	8	.0476	.195	.149	.344	.4026	.375						
FLAS-3R6	553206R	6	.0652	.195	.149	.344	.4026	.375						
FLAS-3L6	553206L	6	.0652	.195	.149	.344	.4026	.375						
FLAS-3R5	553205R	5	.0793	.195	.149	.344	.4026	.375						
FLAS-3L5	553205L	5	.0793	.195	.149	.344	.4026	.375						
FLAS-3R4	553204R	4	.1004	.195	.149	.344	.4026	.375						
FLAS-3L4	553204L	4	.1004	.195	.149	.344	.4026	.375						
FLAS-4R3	554203R	3	.1356	.255	.202	.453	.6332	.375						
FLAS-4L3	554203L	3	.1356	.255	.202	.453	.6332	.375						
FLAS-6R2	556202R	2	.2060	.383	.283	.453	.6308	.375						
FLAS-6L2	556202L	2	.2060	.383	.283	.453	.6308	.375						

In an effort to improve our stock standard grade offering, there are periodic changes. Please see current price list for up to date grade offering.

- High performance choice in optimal conditions.
- ▲ Recommended grade under general conditions.

Material	▲	●
Cast Iron		●
Non-Ferrous		●
Stainless/High Temp	▲	●
Steel	▲	●



## PARTIAL TOPPING ACME THREADING

FLA-PT (with corner radii)

For Flo-Lock acme thread limits see pg. 111,112.

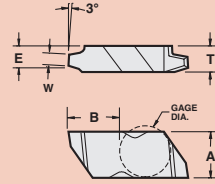

RH Shown

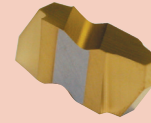

Description	EDP Code	TPI	W	T	E	A	B	Dia.	Gage					
									C3	GP3	GP50	AC3	AC50	
									Uncoated	TIN Coated	AITIN Coated			
FLA-3R16-PT	553016PTR	16	.0206	.195	.149	.344	.4026	.3750						
FLA-3L16-PT	553016PTL	16	.0206	.195	.149	.344	.4026	.3750						
FLA-3R14-PT	553014PTR	14	.0239	.195	.149	.344	.4026	.3750						
FLA-3L14-PT	553014PTL	14	.0239	.195	.149	.344	.4026	.3750						
FLA-3R12-PT	553012PTR	12	.0283	.195	.149	.344	.4026	.3750						
FLA-3L12-PT	553012PTL	12	.0283	.195	.149	.344	.4026	.3750						
FLA-3R10-PT	553010PTR	10	.0319	.195	.149	.344	.4026	.3750						
FLA-3L10-PT	553010PTL	10	.0319	.195	.149	.344	.4026	.3750						
FLA-3R8-PT	553008PTR	8	.0411	.195	.149	.344	.4026	.3750						
FLA-3L8-PT	553008PTL	8	.0411	.195	.149	.344	.4026	.3750						
FLA-3R6-PT	553006PTR	6	.0566	.195	.149	.344	.4026	.3750						
FLA-3L6-PT	553006PTL	6	.0566	.195	.149	.344	.4026	.3750						
FLA-3R5-PT	553005PTR	5	.0689	.195	.149	.344	.4026	.3750						
FLA-3L5-PT	553005PTL	5	.0689	.195	.149	.344	.4026	.3750						
FLA-3R4-PT	553004PTR	4	.0875	.195	.133	.344	.4018	.3750						
FLA-3L4-PT	553004PTL	4	.0875	.195	.133	.344	.4018	.3750						
FLA-4R8-PT	554008PTR	8	.0411	.255	.202	.453	.6332	.3750						
FLA-4L8-PT	554008PTL	8	.0411	.255	.202	.453	.6332	.3750						
FLA-4R6-PT	554006PTR	6	.0566	.255	.202	.453	.6332	.3750						
FLA-4L6-PT	554006PTL	6	.0566	.255	.202	.453	.6332	.3750						
FLA-4R5-PT	554005PTR	5	.0689	.255	.202	.453	.6332	.3750						
FLA-4L5-PT	554005PTL	5	.0689	.255	.202	.453	.6332	.3750						
FLA-4R4-PT	554004PTR	4	.0875	.255	.202	.453	.6332	.3750						
FLA-4L4-PT	554004PTL	4	.0875	.255	.202	.453	.6332	.3750						
FLA-6R3-PT	556003PTR	3	.1184	.383	.283	.453	.6308	.3750						
FLA-6L3-PT	556003PTL	3	.1184	.383	.283	.453	.6308	.3750						
FLA-6R2.5-PT	556025PTR	2.5	.1431	.383	.283	.453	.6308	.3750						
FLA-6L2.5-PT	556025PTL	2.5	.1431	.383	.283	.453	.6308	.3750						
FLA-6R2-PT	556002PTR	2	.1802	.383	.283	.453	.6308	.3750						
FLA-6L2-PT	556002PTL	2	.1802	.383	.283	.453	.6308	.3750						

FLO-LOCK

## PARTIAL TOPPING ACME STUB THREADING

FLAS-PT (with corner radii)

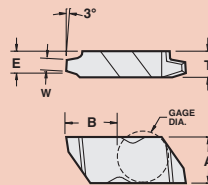

RH Shown



Description	EDP Code	TPI	W	T	E	A	B	Dia.	Gage					
									C3	GP3	GP50	AC3	AC50	
									Uncoated	TIN Coated	AITIN Coated			
FLAS-3R16-PT	553216PTR	16	.0238	.195	.149	.344	.4026	.375						
FLAS-3L16-PT	553216PTL	16	.0238	.195	.149	.344	.4026	.375						
FLAS-3R14-PT	553214PTR	14	.0276	.195	.149	.344	.4026	.375						
FLAS-3L14-PT	553214PTL	14	.0276	.195	.149	.344	.4026	.375						
FLAS-3R12-PT	553212PTR	12	.0326	.195	.149	.344	.4026	.375						
FLAS-3L12-PT	553212PTL	12	.0326	.195	.149	.344	.4026	.375						
FLAS-3R10-PT	553210PTR	10	.0370	.195	.149	.344	.4026	.375						
FLAS-3L10-PT	553210PTL	10	.0370	.195	.149	.344	.4026	.375						
FLAS-3R8-PT	553208PTR	8	.0476	.195	.149	.344	.4026	.375						
FLAS-3L8-PT	553208PTL	8	.0476	.195	.149	.344	.4026	.375						
FLAS-3R6-PT	553206PTR	6	.0652	.195	.149	.344	.4026	.375						
FLAS-3L6-PT	553206PTL	6	.0652	.195	.149	.344	.4026	.375						
FLAS-3R5-PT	553205PTR	5	.0793	.195	.149	.344	.4026	.375						
FLAS-3L5-PT	553205PTL	5	.0793	.195	.149	.344	.4026	.375						
FLAS-3R4-PT	553204PTR	4	.1004	.195	.149	.344	.4026	.375						
FLAS-3L4-PT	553204PTL	4	.1004	.195	.149	.344	.4026	.375						
FLAS-4R3-PT	554203PTR	3	.1356	.255	.202	.453	.6332	.375						
FLAS-4L3-PT	554203PTL	3	.1356	.255	.202	.453	.6332	.375						
FLAS-6R2-PT	556202PTR	2	.2060	.383	.283	.453	.6308	.375						
FLAS-6L2-PT	556202PTL	2	.2060	.383	.283	.453	.6308	.375						

In an effort to improve our stock standard grade offering, there are periodic changes. Please see current price list for up to date grade offering.

- High performance choice in optimal conditions.
- ▲ Recommended grade under general conditions.

Cast Iron		▲		●
Non-Ferrous		▲		●
Stainless/High Temp		▲		●
Steel		▲		●



## AMERICAN STANDARD BUTTRESS 7° LEAD FLT B

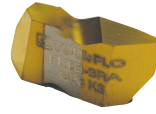
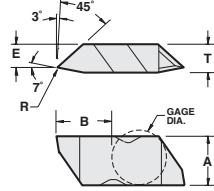

RH Shown

For ASB specifications and application see pg. 111.

Description	EDP Code	TPI	R	T	E	A	B	Gage Dia.	Coating				
									C3	GP3	GP50	AC3	AC50
FLT B-2RA	602801R	16-20	.002/.004	.150	.126	.219	.2688	.1875	●	●	●	●	●
FLT B-2LA	602801L	16-20	.002/.004	.150	.126	.219	.2688	.1875	●	●	●	●	●
FLT B-3RA	603801R	8-16	.005/.008	.195	.164	.344	.4034	.3750	●	●	●	●	●
FLT B-3LA	603801L	8-16	.005/.008	.195	.164	.344	.4034	.3750	●	●	●	●	●
FLT B-4RA	604801R	4-6	.008/.012	.255	.206	.453	.6334	.3750	●	●	●	●	●
FLT B-4LA	604801L	4-6	.008/.012	.255	.206	.453	.6334	.3750	●	●	●	●	●

## AMERICAN STANDARD BUTTRESS 45° LEAD FLT B

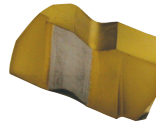
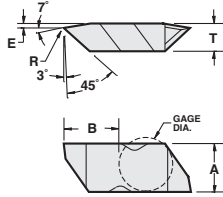

RH Shown

For ASB specifications and application see pg. 111.

Description	EDP Code	TPI	R	T	E	A	B	Gage Dia.	Coating				
									C3	GP3	GP50	AC3	AC50
FLT B-2RB	602802R	16-20	.002/.004	.150	.010	.219	.2627	.1875	●	●	●	●	●
FLT B-2LB	602802L	16-20	.002/.004	.150	.010	.219	.2627	.1875	●	●	●	●	●
FLT B-3RB	603802R	8-16	.005/.008	.195	.012	.344	.3954	.3750	●	●	●	●	●
FLT B-3LB	603802L	8-16	.005/.008	.195	.012	.344	.3954	.3750	●	●	●	●	●
FLT B-4RB	604802R	4-6	.008/.012	.255	.016	.453	.6235	.3750	●	●	●	●	●
FLT B-4LB	604802L	4-6	.008/.012	.255	.016	.453	.6235	.3750	●	●	●	●	●

## API BUTTRESS THREADING FLDC

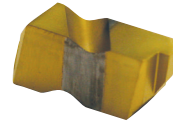
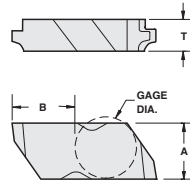

RH EXT Shown

Gage

Description	EDP Code	TPI	TPF	T	A	B	Gage Dia.	Coating				
								C3	GP3	GP50	AC3	AC50
FLDC-3-5B75E	553616E	5	3/4	.250	.344	.4026	.3750	●	●	●	●	●
FLDC-3-5B75I	553616I	5	3/4	.250	.344	.4026	.3750	●	●	●	●	●
FLDC-3-5B1E	553617E	5	1	.250	.344	.4026	.3750	●	●	●	●	●
FLDC-3-5B1I	553617I	5	1	.250	.344	.4026	.3750	●	●	●	●	●
FLDC-4-5B75E	554616E	5	3/4	.255	.453	.6320	.3750	●	●	●	●	●
FLDC-4-5B75I	554616I	5	3/4	.255	.453	.6320	.3750	●	●	●	●	●
FLDC-4-5B1E	554617E	5	1	.255	.453	.6320	.3750	●	●	●	●	●
FLDC-4-5B1I	554617I	5	1	.255	.453	.6320	.3750	●	●	●	●	●

## API THREADING NON TOPPING FLD

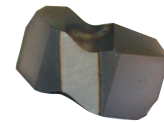
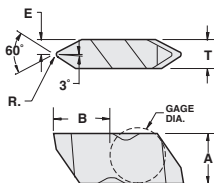

RH Shown

Gage

Description	EDP Code	TPI	R	E	T	A	B	Gage Dia.	Coating				
									C3	GP3	GP50	AC3	AC50
FLD-3038R	553438R	4	.033/.038	.082	.195	.344	.3991	.3750	●	●	●	●	●
FLD-3038L	553438L	4	.033/.038	.082	.195	.344	.3991	.3750	●	●	●	●	●
FLD-3040R	553440R	5	.015/.020	.082	.195	.344	.3991	.3750	●	●	●	●	●
FLD-3040L	553440L	5	.015/.020	.082	.195	.344	.3991	.3750	●	●	●	●	●
FLD-4038R	554438R	4	.033/.038	.128	.255	.453	.6293	.3750	●	●	●	●	●
FLD-4038L	554438L	4	.033/.038	.128	.255	.453	.6293	.3750	●	●	●	●	●
FLD-4040R	554440R	5	.015/.020	.128	.255	.453	.6293	.3750	●	●	●	●	●
FLD-4040L	554440L	5	.015/.020	.128	.255	.453	.6293	.3750	●	●	●	●	●
FLD-4050R	554450R	4	.020/.025	.128	.255	.453	.6293	.3750	●	●	●	●	●
FLD-4050L	554450L	4	.020/.025	.128	.255	.453	.6293	.3750	●	●	●	●	●

In an effort to improve our stock standard grade offering, there are periodic changes. Please see current price list for up to date grade offering.

● High performance choice in optimal conditions.  
▲ Recommended grade under general conditions.

Material	C3	GP3	GP50	AC3	AC50
Cast Iron		▲	●		●
Non-Ferrous		▲	●		●
Stainless/High Temp		▲	●		●
Steel		▲	●		●



# FLO-LOCK

## API ROTARY SHOULDER CONNECTION THREADING

FLDC

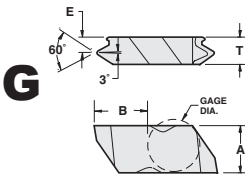

RH EXT Shown

Description	EDP Code	TPI	TPF	E	T	A	B	Gage Dia.	Conn. No. or Size	Coatings				
										GP3	GP50	AC22	AC3	AC50
FLDC-3-530E	553613E	5	3	.147	.250	.344	.4026	.3750	3-1/2 FH, 2-3/8-4-1/2 Reg.	●				
FLDC-3-530I	553613I	5	3	.147	.250	.344	.4026	.3750	3-1/2 FH, 2-3/8-4-1/2 Reg.		●			
FLDC-4-425E	554609E	4	2	.183	.312	.453	.6320	.3750	5-1/2 FH, 6-5/8 FH & Reg.	●	●			
FLDC-4-425I	554609I	4	2	.183	.312	.453	.6320	.3750	5-1/2 FH, 6-5/8 FH & Reg.			●		
FLDC-4-428E	554610E	4	2	.183	.312	.453	.6320	.3750	NC23-NC50, 2-3/8-5-1/2IF	●	●			●
FLDC-4-428I	554610I	4	2	.183	.312	.453	.6320	.3750	NC23-NC50, 2-3/8-5-1/2IF					
FLDC-4-435E	554611E	4	3	.183	.312	.453	.6320	.3750	5-1/2, 7-5/8, 8-5/8 Reg.	●				
FLDC-4-435I	554611I	4	3	.183	.312	.453	.6320	.3750	5-1/2, 7-5/8, 8-5/8 Reg.					
FLDC-4-438E	554612E	4	3	.183	.312	.453	.6320	.3750	NC56 - NC71	●				
FLDC-4-438I	554612I	4	3	.183	.312	.453	.6320	.3750	NC56 - NC71					

## API ROUND THREADING

FLDC

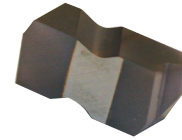
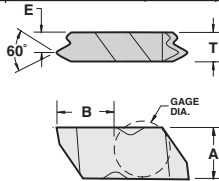

RH Shown

Description	EDP Code	TPI	TPF	E	T	A	B	Gage Dia.	Coatings					
									C3	GP3	GP50	AC3	AC50	
FLDC-3-8RDR75	553632R	8	3/4	.195	.125	.344	.4010	.3750			●			
FLDC-3-8RDL75	553632L	8	3/4	.195	.125	.344	.4010	.3750				●		
FLDC-3-10RDR75	553634R	10	3/4	.195	.125	.344	.4010	.3750			●			
FLDC-3-10RDL75	553634L	10	3/4	.195	.125	.344	.4010	.3750				●		

FLDC

with chipbreaker

Exclusive patented design!

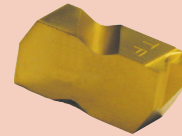
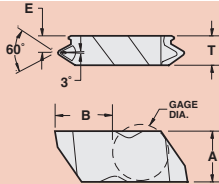

RH Shown

Description	EDP Code	TPI	TPF	E	T	A	B	Gage Dia.	Coatings					
									C3	GP3	GP50	AC3	AC50	
FLDC-3-8RDR75-CB	553632PR	8	3/4	.195	.125	.344	.4010	.3750			●			
FLDC-3-8RDL75-CB	553632PL	8	3/4	.195	.125	.344	.4010	.3750				●		

FLDC

Multi-tooth

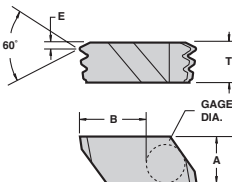

RH Shown

Description	EDP Code	TPI	TPF	E	T	A	B	Gage Dia.	Coatings					
									C3	GP3	GP50	AC3	AC50	
FLDC-6-8RDR75M	556633R	8	3/4	.070	.383	.453	.6360	.3750						
FLDC-6-10RDR75M	556635R	10	3/4	.134	.383	.453	.6360	.3750						

## NPT THREADING

FLDC

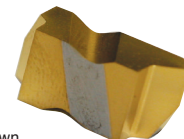
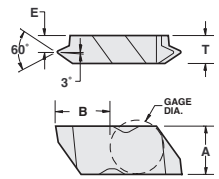

RH Shown

Description	EDP Code	TPI	TPF	E	T	A	B	Gage Dia.	Coatings					
									C3	GP3	GP50	AC3	AC50	
FLDC-38VR-75	553608R	8	3/4	.100	.195	.344	.4000	.3750						
FLDC-38VL-75	553608L	8	3/4	.100	.195	.344	.4000	.3750						
FLDC-3115VR-75	553611R	11.5	3/4	.144	.195	.344	.4000	.3750						
FLDC-3115VL-75	553611L	11.5	3/4	.144	.195	.344	.4000	.3750						
FLDC-314VR-75	553614R	14	3/4	.148	.195	.344	.4023	.3750						
FLDC-314VL-75	553614L	14	3/4	.148	.195	.344	.4023	.3750						
FLDC-318VR-75	553618R	18	3/4	.154	.195	.344	.4023	.3750						
FLDC-318VL-75	553618L	18	3/4	.154	.195	.344	.4023	.3750						
FLDC-327VR-75	553627R	27	3/4	.162	.195	.344	.4023	.3750						
FLDC-327VL-75	553627L	27	3/4	.162	.195	.344	.4023	.3750						

In an effort to improve our stock standard grade offering, there are periodic changes. Please see current price list for up to date grade offering.

- High performance choice in optimal conditions.
- ▲ Recommended grade under general conditions.

Material	GP3	GP50	AC3	AC50
Cast Iron				●
Non-Ferrous				●
Stainless/High Temp				●
Steel			▲	●



## NPT THREADING

FLDC

Multi-tooth

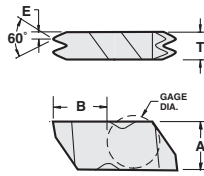

RH Shown



Description	EDP Code	TPI	TPF	E	T	A	B	Gage Dia.	Gage					
									C3	GP3	GP50	AC3	AC50	
FLDC-3-8 NPT-2E	553708E	8	3/4	.058	.250	.344	.4050	.3750						
FLDC-3-8 NPT-2I	553708I	8	3/4	.058	.250	.344	.4050	.3750						
FLDC-3-11.5 NPT-2E	553711E	11.5	3/4	.048	.250	.344	.4050	.3750						
FLDC-3-11.5 NPT-2I	553711I	11.5	3/4	.048	.250	.344	.4050	.3750						

## UNJ THREADING

FLJ

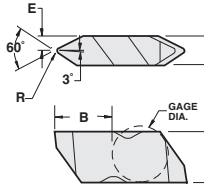

RH Shown

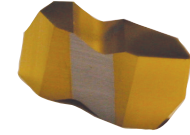

Description	EDP Code	TPI	R	E	T	A	B	Gage Dia.	Gage					
									C3	GP3	GP50	AC3	AC50	
FLJ-3010R16	583216R	16	.0094/.0104	.098	.195	.344	.3999	.3750						
FLJ-3010L16	583216L	16	.0094/.0104	.098	.195	.344	.3999	.3750						
FLJ-3014R12	583212R	12	.0125/.0135	.098	.195	.344	.3999	.3750						
FLJ-3014L12	583212L	12	.0125/.0135	.098	.195	.344	.3999	.3750						
FLJ-3020R8	583208R	8	.0188/.0198	.098	.195	.344	.3999	.3750						
FLJ-3020L8	583208L	8	.0188/.0198	.098	.195	.344	.3999	.3750						

## UNJ THREADING

FLJP

Positive rake

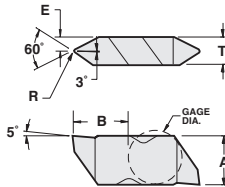

RH Shown

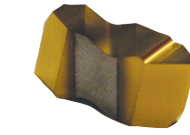

Description	EDP Code	TPI	R	E	T	A	B	Gage Dia.	Gage					
									C3	GP3	GP50	AC3	AC50	
FLJP-3010R16	583816R	16	.0094/.0104	.098	.195	.344	.3999	.3750						
FLJP-3010L16	583816L	16	.0094/.0104	.098	.195	.344	.3999	.3750						
FLJP-3014R12	583812R	12	.0125/.0135	.098	.195	.344	.3999	.3750						
FLJP-3014L12	583812L	12	.0125/.0135	.098	.195	.344	.3999	.3750						
FLJP-3020R8	583808R	8	.0188/.0198	.098	.195	.344	.3999	.3750						
FLJP-3020L8	583808L	8	.0188/.0198	.098	.195	.344	.3999	.3750						

## UNJ FINE PITCH THREADING

FLJF

For cutting close to shoulder

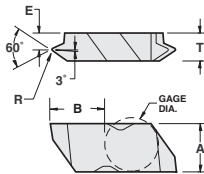

RH Shown

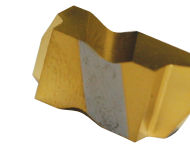

Description	EDP Code	TPI	R	E	T	A	B	Gage Dia.	Gage					
									C3	GP3	GP50	AC3	AC50	
FLJF-3005R32	583432R	32	.0047/.0057	.141	.195	.344	.4022	.3750						
FLJF-3005L32	583432L	32	.0047/.0057	.141	.195	.344	.4022	.3750						
FLJF-3006R28	583428R	28	.0054/.0064	.141	.195	.344	.4022	.3750						
FLJF-3006L28	583428L	28	.0054/.0064	.141	.195	.344	.4022	.3750						
FLJF-3007R24	583424R	24	.0063/.0073	.141	.195	.344	.4022	.3750						
FLJF-3007L24	583424L	24	.0063/.0073	.141	.195	.344	.4022	.3750						
FLJF-3008R20	583420R	20	.0075/.0085	.141	.195	.344	.4022	.3750						
FLJF-3008L20	583420L	20	.0075/.0085	.141	.195	.344	.4022	.3750						
FLJF-3009R18	583418R	18	.0083/.0093	.141	.195	.344	.4022	.3750						
FLJF-3009L18	583418L	18	.0083/.0093	.141	.195	.344	.4022	.3750						
FLJF-3010R16	583416R	16	.0094/.0104	.141	.195	.344	.4022	.3750						
FLJF-3010L16	583416L	16	.0094/.0104	.141	.195	.344	.4022	.3750						
FLJF-3012R14	583414R	14	.0107/.0117	.141	.195	.344	.4022	.3750						
FLJF-3012L14	583414L	14	.0107/.0117	.141	.195	.344	.4022	.3750						

In an effort to improve our stock standard grade offering, there are periodic changes. Please see current price list for up to date grade offering.

- High performance choice in optimal conditions.
- ▲ Recommended grade under general conditions.

	Cast Iron	Non-Ferrous	Stainless/High Temp	Steel
▲				
▲				
▲				





# FLO-LOCK

## UNJ FINE PITCH THREADING

### FLJK

Positive rake

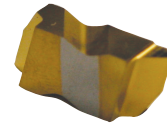
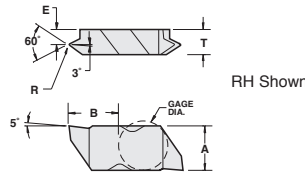

Description	EDP Code	TPI	R	E	T	A	B	Gage Dia.	Gage				
									C3	GP3	GP50	AC3	AC50
FLJK-3005R32	583632R	32	.0047/.0057	.141	.195	.344	.4022	.3750	●	●	●	●	●
FLJK-3005L32	583632L	32	.0047/.0057	.141	.195	.344	.4022	.3750	●	●	●	●	●
FLJK-3006R28	583628R	28	.0054/.0064	.141	.195	.344	.4022	.3750	●	●	●	●	●
FLJK-3006L28	583628L	28	.0054/.0064	.141	.195	.344	.4022	.3750	●	●	●	●	●
FLJK-3007R24	583624R	24	.0063/.0073	.141	.195	.344	.4022	.3750	●	●	●	●	●
FLJK-3007L24	583624L	24	.0063/.0073	.141	.195	.344	.4022	.3750	●	●	●	●	●
FLJK-3008R20	583620R	20	.0075/.0085	.141	.195	.344	.4022	.3750	●	●	●	●	●
FLJK-3008L20	583620L	20	.0075/.0085	.141	.195	.344	.4022	.3750	●	●	●	●	●
FLJK-3009R18	583618R	18	.0083/.0093	.141	.195	.344	.4022	.3750	●	●	●	●	●
FLJK-3009L18	583618L	18	.0083/.0093	.141	.195	.344	.4022	.3750	●	●	●	●	●
FLJK-3010R16	583616R	16	.0094/.0104	.141	.195	.344	.4022	.3750	●	●	●	●	●
FLJK-3010L16	583616L	16	.0094/.0104	.141	.195	.344	.4022	.3750	●	●	●	●	●
FLJK-3012R14	583614R	14	.0107/.0117	.141	.195	.344	.4022	.3750	●	●	●	●	●
FLJK-3012L14	583614L	14	.0107/.0117	.141	.195	.344	.4022	.3750	●	●	●	●	●

## UN THREADING

### FLTC

Crest topping

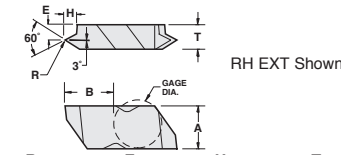

Description	EDP Code	TPI	R	E	H	T	A	B	Gage Dia.	Gage				
										C3	GP3	GP50	AC3	AC50
FLTC-3R7E	613007R	7	.017	.107	.108	.195	.344	.4004	.3750	●	●	●	●	●
FLTC-3L7E	613007L	7	.017	.107	.108	.195	.344	.4004	.3750	●	●	●	●	●
FLTC-3R7I	613207R	7	.009	.107	.092	.195	.344	.4004	.3750	●	●	●	●	●
FLTC-3L7I	613207L	7	.009	.107	.092	.195	.344	.4004	.3750	●	●	●	●	●
FLTC-3R8E	613008R	8	.015	.107	.094	.195	.344	.4004	.3750	●	●	●	●	●
FLTC-3L8E	613008L	8	.015	.107	.094	.195	.344	.4004	.3750	●	●	●	●	●
FLTC-3R8I	613208R	8	.007	.107	.081	.195	.344	.4004	.3750	●	●	●	●	●
FLTC-3L8I	613208L	8	.007	.107	.081	.195	.344	.4004	.3750	●	●	●	●	●
FLTC-3R9E	613009R	9	.013	.107	.084	.195	.344	.4004	.3750	●	●	●	●	●
FLTC-3L9E	613009L	9	.013	.107	.084	.195	.344	.4004	.3750	●	●	●	●	●
FLTC-3R9I	613209R	9	.006	.107	.072	.195	.344	.4004	.3750	●	●	●	●	●
FLTC-3L9I	613209L	9	.006	.107	.072	.195	.344	.4004	.3750	●	●	●	●	●
FLTC-3R10E	613010R	10	.012	.107	.076	.195	.344	.4004	.3750	●	●	●	●	●
FLTC-3L10E	613010L	10	.012	.107	.076	.195	.344	.4004	.3750	●	●	●	●	●
FLTC-3R10I	613210R	10	.005	.107	.065	.195	.344	.4004	.3750	●	●	●	●	●
FLTC-3L10I	613210L	10	.005	.107	.065	.195	.344	.4004	.3750	●	●	●	●	●
FLTC-3R11E	613011R	11	.011	.107	.069	.195	.344	.4004	.3750	●	●	●	●	●
FLTC-3L11E	613011L	11	.011	.107	.069	.195	.344	.4004	.3750	●	●	●	●	●
FLTC-3R11I	613211R	11	.005	.107	.059	.195	.344	.4004	.3750	●	●	●	●	●
FLTC-3L11I	613211L	11	.005	.107	.059	.195	.344	.4004	.3750	●	●	●	●	●
FLTC-3R12E	613012R	12	.010	.148	.051	.195	.344	.4025	.3750	●	●	●	●	●
FLTC-3L12E	613012L	12	.010	.148	.051	.195	.344	.4025	.3750	●	●	●	●	●
FLTC-3R12I	613212R	12	.004	.148	.048	.195	.344	.4025	.3750	●	●	●	●	●
FLTC-3L12I	613212L	12	.004	.148	.048	.195	.344	.4025	.3750	●	●	●	●	●
FLTC-3R14E	613014R	14	.009	.148	.054	.195	.344	.4025	.3750	●	●	●	●	●
FLTC-3L14E	613014L	14	.009	.148	.054	.195	.344	.4025	.3750	●	●	●	●	●
FLTC-3R14I	613214R	14	.003	.148	.044	.195	.344	.4025	.3750	●	●	●	●	●
FLTC-3L14I	613214L	14	.003	.148	.044	.195	.344	.4025	.3750	●	●	●	●	●
FLTC-3R16E	613016R	16	.008	.148	.046	.195	.344	.4025	.3750	●	●	●	●	●
FLTC-3L16E	613016L	16	.008	.148	.046	.195	.344	.4025	.3750	●	●	●	●	●
FLTC-3R16I	613216R	16	.003	.148	.040	.195	.344	.4025	.3750	●	●	●	●	●
FLTC-3L16I	613216L	16	.003	.148	.040	.195	.344	.4025	.3750	●	●	●	●	●
FLTC-3R18E	613018R	18	.007	.148	.041	.195	.344	.4025	.3750	●	●	●	●	●
FLTC-3L18E	613018L	18	.007	.148	.041	.195	.344	.4025	.3750	●	●	●	●	●
FLTC-3R18I	613218R	18	.003	.148	.036	.195	.344	.4025	.3750	●	●	●	●	●
FLTC-3L18I	613218L	18	.003	.148	.036	.195	.344	.4025	.3750	●	●	●	●	●
FLTC-3R20E	613020R	20	.006	.148	.037	.195	.344	.4025	.3750	●	●	●	●	●
FLTC-3L20E	613020L	20	.006	.148	.037	.195	.344	.4025	.3750	●	●	●	●	●
FLTC-3R20I	613220R	20	.003	.148	.031	.195	.344	.4025	.3750	●	●	●	●	●
FLTC-3L20I	613220L	20	.003	.148	.031	.195	.344	.4025	.3750	●	●	●	●	●
FLTC-3R24E	613024R	24	.005	.148	.031	.195	.344	.4025	.3750	●	●	●	●	●
FLTC-3L24E	613024L	24	.005	.148	.031	.195	.344	.4025	.3750	●	●	●	●	●
FLTC-3R24I	613224R	24	.003	.148	.026	.195	.344	.4025	.3750	●	●	●	●	●
FLTC-3L24I	613224L	24	.003	.148	.026	.195	.344	.4025	.3750	●	●	●	●	●
FLTC-3R28*	613028R	28	.003	.148	.023	.195	.344	.4025	.3750	●	●	●	●	●
FLTC-3L28*	613028L	28	.003	.148	.023	.195	.344	.4025	.3750	●	●	●	●	●
FLTC-3R32*	613228R	32	.003	.148	.021	.195	.344	.4025	.3750	●	●	●	●	●
FLTC-3L32*	613228L	32	.003	.148	.021	.195	.344	.4025	.3750	●	●	●	●	●

\*Will work for either internal or external.

In an effort to improve our stock standard grade offering, there are periodic changes. Please see current price list for up to date grade offering.

- High performance choice in optimal conditions.
- ▲ Recommended grade under general conditions.

Material	▲	●
Cast Iron	▲	●
Non-Ferrous	▲	●
Stainless/High Temp	▲	●
Steel	▲	●



## 60° V-THREADING

FLTF

Fine pitch

For 60° V-thread limits see pg. 112.

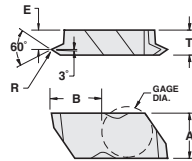

RH Shown

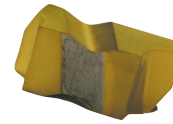

Description	EDP Code	TPI		R	E	T	A	B	Dia.	Gage						
		Int	Ext							C25	GP3	GP4	GP50	GP520	AC3	AC50
FLTF-2R	612400R	12-24	14-44	.002/.004	.110	.150	.219	.2679	.1875	●	●	●	●	●	●	●
FLTF-2L	612400L	12-24	14-44	.002/.004	.110	.150	.219	.2679	.1875	●	●	●	●	●	●	●
FLTF-3R	613400R	9-24	10-44	.002/.004	.141	.195	.344	.4022	.3750	●	●	●	●	●	●	●
FLTF-3L	613400L	9-24	10-44	.002/.004	.141	.195	.344	.4022	.3750	●	●	●	●	●	●	●
FLTF-4R	614400R	9-24	10-44	.002/.004	.201	.255	.453	.6322	.3750	●	●	●	●	●	●	●
FLTF-4L	614400L	9-24	10-44	.002/.004	.201	.255	.453	.6322	.3750	●	●	●	●	●	●	●

## 60° V-THREADING

FLTK

Positive rake

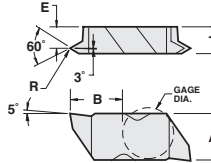

RH Shown

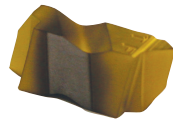

Description	EDP Code	TPI		R	E	T	A	B	Dia.	Gage						
		Int	Ext							C25	GP3	GP4	GP50	GP520	AC3	AC50
FLTK-2R	612600R	12-24	14-44	.002/.004	.110	.150	.219	.2679	.1875	●	●	●	●	●	●	●
FLTK-2L	612600L	12-24	14-44	.002/.004	.110	.150	.219	.2679	.1875	●	●	●	●	●	●	●
FLTK-3R	613600R	9-24	10-44	.002/.004	.141	.195	.344	.4022	.3750	●	●	●	●	●	●	●
FLTK-3L	613600L	9-24	10-44	.002/.004	.141	.195	.344	.4022	.3750	●	●	●	●	●	●	●
FLTK-4R	614600R	9-24	10-44	.002/.004	.201	.255	.453	.6322	.3750	●	●	●	●	●	●	●
FLTK-4L	614600L	9-24	10-44	.002/.004	.201	.255	.453	.6322	.3750	●	●	●	●	●	●	●

## 60° V-THREADING - CHIP-FLO

FLT-CB

Features:

- Patented chipbreaker - Patent No. 6,146,064
- Maximum chip control
- Fewer scarred threads
- For coarse and fine pitches

Exclusive patented design!

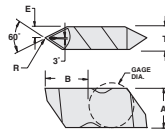

RH Shown

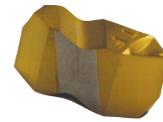

Description	EDP Code	TPI		R	E	T	A	B	Gage Dia.	Gage						
		Int	Ext							C25	C3	GP22	GP4	GP50	AC22	AC3
FLT-3R-HCB	603600HCR	5-12	6-20	.005/.008	.098	.195	.344	.3999	.3750	●	●	●	●	●	●	●
FLT-3L-HCB	603600HCL	5-12	6-20	.005/.008	.098	.195	.344	.3999	.3750	●	●	●	●	●	●	●
FLT-3RC-HCB	603612HCR	5-6	6-11	.012/.015	.098	.195	.344	.3999	.3750	●	●	●	●	●	●	●
FLT-3LC-HCB	603612HCL	5-6	6-11	.012/.015	.098	.195	.344	.3999	.3750	●	●	●	●	●	●	●
FLT-3R-CB	603600CR	8-12	8-20	.005/.008	.098	.195	.344	.3999	.3750	●	●	●	●	●	●	●
FLT-3L-CB	603600CL	8-12	8-20	.005/.008	.098	.195	.344	.3999	.3750	●	●	●	●	●	●	●
FLT-3R-FCB	603600FCR	7-20	8-36	.003/.005	.098	.195	.344	.3999	.3750	●	●	●	●	●	●	●
FLT-3L-FCB	603600FCL	7-20	8-36	.003/.005	.098	.195	.344	.3999	.3750	●	●	●	●	●	●	●
FLT-4R-HCB	604600HCR	4-12	4-20	.005/.008	.128	.255	.453	.6298	.3750	●	●	●	●	●	●	●
FLT-4L-HCB	604600HCL	4-12	4-20	.005/.008	.128	.255	.453	.6298	.3750	●	●	●	●	●	●	●

## 60° V-THREADING

FLT

For 60° V-thread limits see pg. 112.

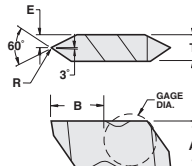

RH Shown

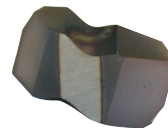

Description	EDP Code	TPI		R	E	T	A	B	Gage Dia.	Gage						
		Int	Ext							C25	GP3	GP4	GP50	AC22	AC3	AC50
FLT-2R	602600R	7-20	8-36	.003/.005	.075	.150	.219	.2661	.1875	●	●	●	●	●	●	●
FLT-2L	602600L	7-20	8-36	.003/.005	.075	.150	.219	.2661	.1875	●	●	●	●	●	●	●
FLT-3R	603600R	5-12	6-20	.005/.008	.098	.195	.344	.3999	.3750	●	●	●	●	●	●	●
FLT-3L	603600L	5-12	6-20	.005/.008	.098	.195	.344	.3999	.3750	●	●	●	●	●	●	●
FLT-3010R	603610R	5-12	6-18	.009/.011	.098	.195	.344	.3999	.3750	●	●	●	●	●	●	●
FLT-3010L	603610L	5-12	6-18	.009/.011	.098	.195	.344	.3999	.3750	●	●	●	●	●	●	●
FLT-4R	604600R	4-12	4-20	.005/.008	.128	.255	.453	.6298	.3750	●	●	●	●	●	●	●
FLT-4L	604600L	4-12	4-20	.005/.008	.128	.255	.453	.6298	.3750	●	●	●	●	●	●	●

In an effort to improve our stock standard grade offering, there are periodic changes. Please see current price list for up to date grade offering.

- High performance choice in optimal conditions.
- ▲ Recommended grade under general conditions.

Material	C25	GP3	GP4	GP50	AC22	AC3	AC50
Cast Iron	▲						●
Non-Ferrous							●
Stainless/High Temp	▲						●
Steel			▲	▲			●



# FLO-LOCK

## 60° V-THREADING

FLTP

Positive rake

For 60° V-thread limits see pg. 112.

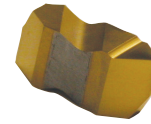
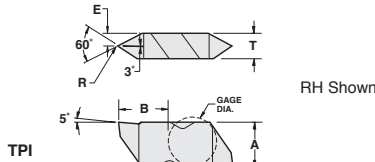

Description	EDP Code	Int	Ext	R	E	T	A	B	Dia.	Gage				
										C25	GP3	GP50	AC3	AC50
FLTP-2R	612800R	7-20	8-36	.003/.005	.075	.150	.219	.2661	.1875	●	●	●	●	●
FLTP-2L	612800L	7-20	8-36	.003/.005	.075	.150	.219	.2661	.1875	●	●	●	●	●
FLTP-3R	613800R	5-12	6-20	.005/.008	.098	.195	.344	.3999	.3750	●	●	●	●	●
FLTP-3L	613800L	5-12	6-20	.005/.008	.098	.195	.344	.3999	.3750	●	●	●	●	●
FLTP-4R	614800R	4-12	4-20	.005/.008	.128	.255	.453	.6293	.3750	●	●	●	●	●
FLTP-4L	614800L	4-12	4-20	.005/.008	.128	.255	.453	.6293	.3750	●	●	●	●	●

## UNDERCUTTING

FLU

For use in FLRR/L holders

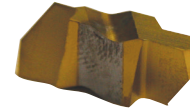
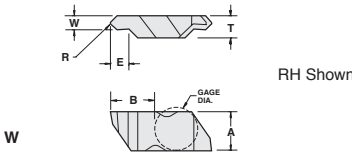

Description	EDP Code	Inch	Metric	R	E	T	A	B	Dia.	Gage				
										C3	GP3	GP50	AC3	AC50
FLU-3094R	623094R	.094	2,39	.020	.125	.195	.344	.4050	.3750	●	●	●	●	●
FLU-3094L	623094L	.094	2,39	.020	.125	.195	.344	.4050	.3750	●	●	●	●	●
FLU-3125R	623125R	.125	3,18	.047	.188	.195	.344	.4050	.3750	●	●	●	●	●
FLU-3125L	623125L	.125	3,18	.047	.188	.195	.344	.4050	.3750	●	●	●	●	●
FLU-3156R	623156R	.156	3,96	.047	.188	.195	.344	.4050	.3750	●	●	●	●	●
FLU-3156L	623156L	.156	3,96	.047	.188	.195	.344	.4050	.3750	●	●	●	●	●

## POLY-V

FLV

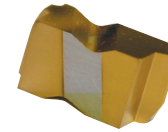
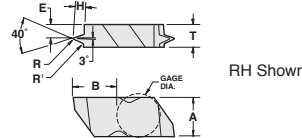

Description	EDP Code	R	R1	E	T	H	A	B	Dia.	Gage				
										C25	GP3	GP50	AC3	AC50
FLV-3RJ	623800R	.012	.008	.125	.195	.087	.344	.4013	.3750	●	●	●	●	●
FLV-3LJ	623800L	.012	.008	.125	.195	.087	.344	.4013	.3750	●	●	●	●	●
FLV-4RL	624800R	.012	.015	.118	.255	.201	.453	.6288	.3750	●	●	●	●	●
FLV-4LL	624800L	.012	.015	.118	.255	.201	.453	.6288	.3750	●	●	●	●	●

In an effort to improve our stock standard grade offering, there are periodic changes. Please see current price list for up to date grade offering.

- High performance choice in optimal conditions.
- ▲ Recommended grade under general conditions.

Material	Cast Iron	Non-Ferrous	Stainless/High Temp	Steel
Grade	▲	▲	▲	▲

## EXTERNAL HOLDER (INCH)

FLSR/L

Threading and Grooving

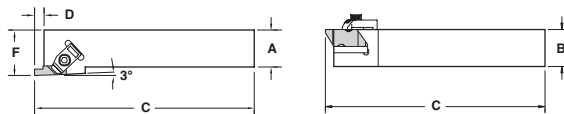

RH SHOWN

Most holders available with coolant port (ie: Add CP to end of description)

Description	EDP Code	Insert	A	B	C	D	F*	Seat		Clamp	Clamp Screw
								Seat	Screw		
FLSR-62	93400608C	FL_-2R	3/8	3/8	2-1/2	.14	.562	-	-	TF-74	S-310
FLSL-62	93300608C	FL_-2L	3/8	3/8	2-1/2	.14	.562	-	-	TF-75	S-310
FLSR-82V	93400808V	FL_-2R	1/2	1/2	3-1/2	.14	.750	-	-	TF-74	S-310
FLSL-82V	93300808V	FL_-2L	1/2	1/2	3-1/2	.14	.750	-	-	TF-75	S-310
FLSR-102B	93401008B	FL_-2R	5/8	5/8	4-1/2	.14	1.000	-	-	TF-74	S-310
FLSR-122B	93401208B	FL_-2R	3/4	3/4	4-1/2	.14	1.000	-	-	TF-74	S-310
FLSL-122B	93301208B	FL_-2L	3/4	3/4	4-1/2	.14	1.000	-	-	TF-75	S-310
FLSR-162C	93401608C	FL_-2R	1	1.000	5	.14	1.250	-	-	TF-74	S-310
FLSL-162C	93301608C	FL_-2L	1	1.000	5	.14	1.250	-	-	TF-75	S-310
FLSR-123B	93401216B	FL_-3R	3/4	3/4	4-1/2	.21	1.000	-	-	TF-72	S-412
FLSL-123B	93301216B	FL_-3L	3/4	3/4	4-1/2	.21	1.000	-	-	TF-73	S-412
FLSR-163C	93401616C	FL_-3R	1	1	5	.21	1.250	-	-	TF-72	S-412
FLSL-163C	93301616C	FL_-3L	1	1	5	.21	1.250	-	-	TF-73	S-412
FLSR-163D	93401616D	FL_-3R	1	1	6	.21	1.250	-	-	TF-72	S-412
FLSL-163D	93301616D	FL_-3L	1	1	6	.21	1.250	-	-	TF-73	S-412
FLSR-203D	93402016D	FL_-3R	1-1/4	1-1/4	6	.21	1.500	-	-	TF-72	S-412
FLSL-203D	93302016D	FL_-3L	1-1/4	1-1/4	6	.21	1.500	-	-	TF-73	S-412
FLSR-164D	93401620D	FL_-4R	1	1	6	.29	1.250	SM-420	SL-344	TF-72	S-412
FLSL-164D	93301620D	FL_-4L	1	1	6	.29	1.250	SM-420	SL-344	TF-73	S-412
FLSR-204D	93402020D	FL_-4R	1-1/4	1-1/4	6	.29	1.500	SM-420	SL-344	TF-72	S-412
FLSL-204D	93302020D	FL_-4L	1-1/4	1-1/4	6	.29	1.500	SM-420	SL-344	TF-73	S-412
FLSR-205D	93402024D	FL_-5R	1-1/4	1-1/4	6	.40	1.500	-	-	TF-80	S-352
FLSL-205D	93302024D	FL_-5L	1-1/4	1-1/4	6	.40	1.500	-	-	TF-81	S-352
FLSR-206D	93402028D	FL_-6R	1-1/4	1-1/4	6	.29	1.500	SM-416	S-111	TF-120	S-412
FLSL-206D	93302028D	FL_-6L	1-1/4	1-1/4	6	.29	1.500	SM-416	S-111	TF-121	S-412

\* "F" Dim. over sharp point of grooving insert.



## EXTERNAL HOLDER (METRIC)

FLSR/L

Threading and Grooving

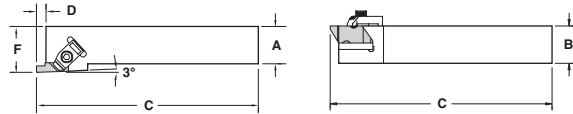

RH SHOWN

Most holders available with coolant port (ie: Add CP to end of description)

Description	EDP Code	Insert	A	B	C	D	F*	Seat	Seat Screw	Clamp	Clamp Screw
FLSR-2020M2	93412008	FL_-2R	20,0	20,0	125,0	3,0	25,0	-	-	TF-74	S-310
FLSL-2020M2	93312008	FL_-2L	20,0	20,0	125,0	3,0	25,0	-	-	TF-75	S-310
FLSR-2525M2	93412508	FL_-2R	25,0	25,0	150,0	3,0	32,0	-	-	TF-74	S-310
FLSL-2525M2	93312508	FL_-2L	25,0	25,0	150,0	3,0	32,0	-	-	TF-75	S-310
FLSR-2020M3	93412016	FL_-3R	20,0	20,0	125,0	5,0	32,0	-	-	TF-72	S-412
FLSL-2020M3	93312016	FL_-3L	20,0	20,0	125,0	5,0	32,0	-	-	TF-73	S-412
FLSR-2525M3	93412516	FL_-3R	25,0	25,0	150,0	5,0	32,0	-	-	TF-72	S-412
FLSL-2525M3	93312516	FL_-3L	25,0	25,0	150,0	5,0	32,0	-	-	TF-73	S-412

\* "F" Dim. over sharp point of grooving insert.

## EXTERNAL HOLDER (INCH)

FLER/L

Threading and Grooving

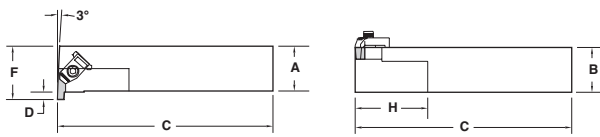

RH SHOWN

Most holders available with coolant port (ie: Add CP to end of description)

Description	EDP Code	Insert	A	B	C	D	F*	H	Clamp	Clamp Screw
FLER-82V	93100808V	FL_-2L	1/2	1/2	3-1/2	.14	.750	1	TF-75	S-310
FLER-122B	93101208B	FL_-2L	3/4	3/4	4-1/2	.14	1.000	1	TF-75	S-310
FLEL-122B	93001208B	FL_-2R	3/4	3/4	4-1/2	.14	1.000	1	TF-74	S-310
FLER-162C	93101608C	FL_-2L	1	1	5	.14	1.250	1	TF-75	S-310
FLEL-162C	93001608C	FL_-2R	1	1	5	.14	1.250	1	TF-74	S-310
FLER-123B	93101216B	FL_-3L	3/4	3/4	4-1/2	.21	1.125	2	TF-73	S-412
FLEL-123B	93001216B	FL_-3R	3/4	3/4	4-1/2	.21	1.125	2	TF-72	S-412
FLER-163D	93101616D	FL_-3L	1	1	6.000	.21	1.250	2	TF-73	S-412
FLEL-163D	93001616D	FL_-3R	1	1	6.000	.21	1.250	2	TF-72	S-412
FLER-203D	93102016D	FL_-3L	1-1/4	1-1/4	6.000	.21	1.500	2	TF-73	S-412
FLEL-203D	93002016D	FL_-3R	1-1/4	1-1/4	6.000	.21	1.500	2	TF-72	S-412
FLER-164D	93101620D	FL_-4L	1	1	6.000	.29	1.375	2	TF-73	S-412
FLEL-164D	93001620D	FL_-4R	1	1	6.000	.29	1.375	2	TF-72	S-412
FLER-204D	93102020D	FL_-4L	1-1/4	1-1/4	6.000	.29	1.625	2	TF-73	S-412
FLEL-204D	93002020D	FL_-4R	1-1/4	1-1/4	6.000	.29	1.625	2	TF-72	S-412
FLER-205D	93102024D	FL_-5L	1-1/4	1-1/4	6.000	.29	2.000	2	TF-81	S-352
FLEL-205D	93002024D	FL_-5R	1-1/4	1-1/4	6.000	.29	2.000	2	TF-80	S-352
FLER-206D	93102028D	FL_-6L	1-1/4	1-1/4	6.000	.29	1.625	2	TF-121	S-412
FLEL-206D	93002028D	FL_-6R	1-1/4	1-1/4	6.000	.29	1.625	2	TF-120	S-412

\* C&F measured over sharp point of grooving insert.

## EXTERNAL HOLDER (INCH)

FLASR/L

Threading and Grooving

Design for Swiss machines

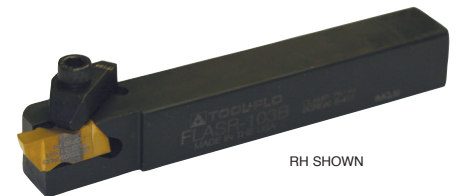
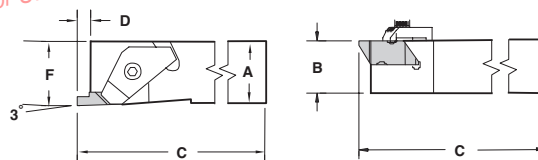

RH SHOWN

Most holders available with coolant port (ie: Add CP to end of description)

Description	EDP Code	Insert	A	B	C	D	F	Clamp	Clamp Screw
FLASR-062D	92900608D	FL_-2R	3/8	3/8	6	.138	.375	TF-182	S-310
FLASL-062D	92650608D	FL_-2L	3/8	3/8	6	.138	.375	TF-183	S-310
FLASR-082D	92900808D	FL_-2R	1/2	1/2	6	.138	.500	TF-182	S-310
FLASL-082D	92650808D	FL_-2L	1/2	1/2	6	.138	.500	TF-183	S-310
FLASR-102B	92901008B	FL_-2R	5/8	5/8	4-1/2	.138	.625	TF-184	S-412
FLASR-103B	92901016B	FL_-3R	5/8	5/8	4-1/2	.21	.625	TF-184	S-412
FLASL-103B	92891016B	FL_-3L	5/8	5/8	4-1/2	.21	.625	TF-185	S-412

\* "F" Dim. over sharp point of grooving insert.



# FLO-LOCK

## EXTERNAL HOLDER (METRIC)

FLASR/L

Threading and Grooving

*Design for Swiss machines*

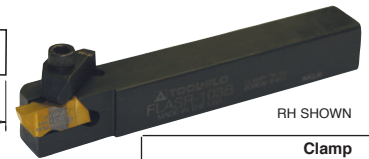
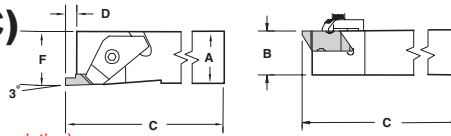

RH SHOWN

Most holders available with coolant port (ie: Add CP to end of description)

Description	EDP Code	Insert	A	B	C	D	F	Clamp	Clamp Screw
FLASR-1010M2	92711008	FL_-2R	10,0	10,0	150,0	3,51	10,0	TF-182	S-310
FLASL-1010M2	92661008	FL_-2L	10,0	10,0	150,0	3,51	10,0	TF-183	S-310
FLASR-1212M2	92711208	FL_-2R	12,0	12,0	150,0	3,51	12,0	TF-182	S-310
FLASL-1212M2	92661208	FL_-2L	12,0	12,0	150,0	3,51	12,0	TF-183	S-310
FLASR-1616M2	92711608	FL_-2R	16,0	16,0	150,0	3,51	16,0	TF-184	S-412
FLASR-1616M3	92711616	FL_-3R	16,0	16,0	125,0	5,31	16,0	TF-184	S-412
FLASL-1616M3	92661616	FL_-3L	16,0	16,0	125,0	5,31	16,0	TF-185	S-412

## EXTERNAL HOLDER (INCH)

FLRR/L

Undercutting

Most holders available with coolant port (ie: Add CP to end of description)

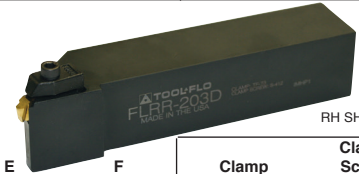
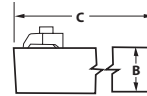
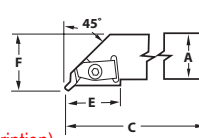

RH SHOWN

Description	EDP Code	Insert	A	B	C	E	F	Clamp	Clamp Screw
FLRR-123B	93201216B	FLU-3L	3/4	3/4	4-1/2	1-1/4	1.000	TF-73	S-412
FLRL-123B	93181216B	FLU-3R	3/4	3/4	4-1/2	1-1/4	1.000	TF-72	S-412
FLRR-163D	93201616D	FLU-3L	1	1	6	1-1/4	1.250	TF-73	S-412
FLRL-163D	93181616D	FLU-3R	1	1	6	1-1/4	1.250	TF-72	S-412
FLRR-203D	93202016D	FLU-3L	1-1/4	1-1/4	6	1-1/4	1.500	TF-73	S-412
FLRL-203D	93182016D	FLU-3R	1-1/4	1-1/4	6	1-1/4	1.500	TF-72	S-412

## INTERNAL HOLDER (INCH)

A-FLER/L

Threading and Grooving

Coolant hole

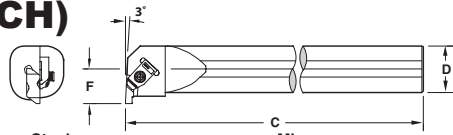

RH SHOWN

Description	EDP Code	Stock Status	Insert	Min. Bore	D	C	F	Clamp	Clamp Screw
A08-FLER2	96500808	●	FL-2L	.730	.500	8	.437	TF-147	S-310
A08-FLEL2	96400808	●	FL-2R	.730	.500	8	.437	TF-146	S-310
A10-FLER2	96501008	●	FL-2L	1.000	.625	10	.500	TF-75	S-310
A12-FLER2	96501208	●	FL-2L	1.125	.750	10	.562	TF-75	S-310
A12-FLEL2	96401208	●	FL-2R	1.125	.750	10	.562	TF-74	S-310
A16-FLER2	96501608	●	FL-2L	1.375	1.000	12	.688	TF-75	S-310
A16-FLEL2	96401608	●	FL-2R	1.375	1.000	12	.688	TF-74	S-310
A16-FLER3	96501616	●	FL-3L	1.375	1.000	12	.688	TF-73	S-412
A16-FLEL3	96401616	●	FL-3R	1.375	1.000	12	.688	TF-72	S-412
A20-FLER3	96502016	○	FL-3L	1.750	1.250	14	.875	TF-73	S-412
A20-FLEL3	96402016	○	FL-3R	1.750	1.250	14	.875	TF-72	S-412
A24-FLER3	96502416	●	FL-3L	2.000	1.500	14	1.000	TF-73	S-412
A24-FLEL3	96402416	●	FL-3R	2.000	1.500	14	1.000	TF-72	S-412
A28-FLER3	96502816	○	FL-3L	2.250	1.750	14	1.125	TF-73	S-412
A32-FLER3	96503216	●	FL-3L	2.500	2.000	16	1.250	TF-73	S-412
A32-FLEL3	96403216	●	FL-3R	2.500	2.000	16	1.250	TF-72	S-412
A28-FLER4	96502820	●	FL-4L	2.250	1.750	14	1.250	TF-73	S-412
A28-FLEL4	96402820	●	FL-4R	2.250	1.750	14	1.250	TF-72	S-412
A32-FLER4	96503220	●	FL-4L	2.750	2.000	16	1.296	TF-73	S-412
A32-FLEL4	96403220	●	FL-4R	2.750	2.000	16	1.296	TF-72	S-412
A32-FLER5	96503224	●	FL-5L	2.812	2.000	16	1.406	CM-81	S-352
A32-FLER6	96503228	●	FL-6L	2.750	2.000	16	1.375	CM-121	S-412

\*F and \*C Dim. over sharp point of grooving insert.

## INTERNAL HOLDER (METRIC)

A\_M-FLER/L

Threading and Grooving

Coolant hole

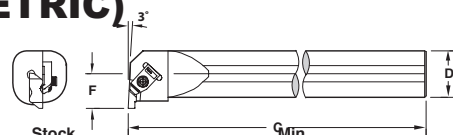

RH SHOWN

Description	EDP Code	Stock Status	Insert	Min. Bore	D	C	F	Clamp	Clamp Screw
A16M-FLER2	96441608	●	FL-2L	25,4	16,0	250,0	12,65	TF-75	S-310
A20M-FLER2	96442008	●	FL-2L	28,6	20,0	250,0	13,8	TF-75	S-310
A25M-FLER2	96442508	●	FL-2L	34,9	25,0	300,0	17,7	TF-75	S-310
A25M-FLEL2	96432508	●	FL-2R	34,9	25,0	300,0	17,7	TF-74	S-310
A25M-FLER3	96442516	●	FL-3L	34,9	25,0	300,0	17,7	TF-73	S-412
A25M-FLEL3	96432516	●	FL-3R	34,9	25,0	300,0	17,7	TF-72	S-412
A32M-FLER3	96443216	○	FL-3L	44,45	32,0	350,0	22,1	TF-73	S-412
A32M-FLEL3	96433216	○	FL-3R	44,45	32,0	350,0	22,1	TF-72	S-412
A40M-FLER3	96444016	●	FL-3L	50,8	40,0	350,0	24,45	TF-73	S-412
A40M-FLEL3	96434016	●	FL-3R	50,8	40,0	350,0	24,45	TF-72	S-412
A50M-FLER4	96445020	●	FL-4L	63,5	50,0	400,0	35,3	TF-72	S-412
A50M-FLEL4	96435020	●	FL-4R	63,5	50,0	400,0	35,3	TF-72	S-412

\*F and \*C Dim. over sharp point of grooving insert.

FLO-LOCK



# EXTERNAL HOLDER

## FLSRLT

For double ended FLGT/FLRT inserts  
Inch

*Exclusive TOOL-FLO design!*

Most holders available with coolant port  
(ie: Add CP to end of description)

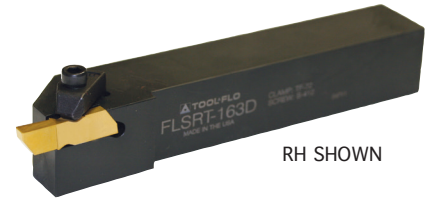
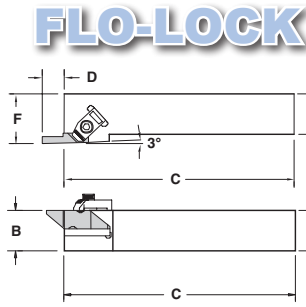

Description	EDP Code	Insert	A	B	C	D	F	Clamp	Clamp Screw
FLSRT-163D	93431616D	FLGT-3R	1.000	1.000	6.000	.440	1.250	TF-72	S-412
FLSLT-163D	93421616D	FLGT-3L	1.000	1.000	6.000	.440	1.250	TF-73	S-412
FLSRT-203D	93432016D	FLGT-3R	1.250	1.250	6.000	.440	1.500	TF-72	S-412
FLSLT-203D	93422016D	FLGT-3L	1.250	1.250	6.000	.440	1.500	TF-73	S-412
FLSRT-164D	93431620D	FLGT-4R	1.000	1.000	6.000	.560	1.250	TF-72	S-412
FLSLT-164D	93421620D	FLGT-4L	1.000	1.000	6.000	.560	1.250	TF-73	S-412
FLSRT-204D	93432020D	FLGT-4R	1.250	1.250	6.000	.560	1.500	TF-72	S-412
FLSLT-204D	93422020D	FLGT-4L	1.250	1.250	6.000	.560	1.500	TF-73	S-412

## METRIC

Description	EDP Code	Insert	A	B	C	D	F	Clamp	Clamp Screw
FLSRT-2525M3	934325M16	FLGT/RT-3R	25,0	25,0	152,4	11,2	32,0	TF-72	S-412
FLSLT-2525M3	934225M16	FLGT/RT-3L	25,0	25,0	152,4	11,2	32,0	TF-73	S-412
FLSRT-3232M3	934332M16	FLGT/RT-3R	32,0	32,0	152,4	11,2	40,0	TF-72	S-412
FLSLT-3232M3	934232M16	FLGT/RT-3L	32,0	32,0	152,4	11,2	40,0	TF-73	S-412
FLSRT-2525M4	934325M20	FLGT/RT-4R	25,0	25,0	152,4	14,2	32,0	TF-72	S-412
FLSLT-2525M4	934225M20	FLGT/RT-4L	25,0	25,0	152,4	14,2	32,0	TF-73	S-412
FLSRT-3232M4	934332M20	FLGT/RT-4R	32,0	32,0	152,4	14,2	40,0	TF-72	S-412
FLSLT-3232M4	934232M20	FLGT/RT-4L	32,0	32,0	152,4	14,2	40,0	TF-73	S-412

## FLERLT

For double ended FLGT/FLRT inserts  
Inch

*Exclusive TOOL-FLO design!*

Most holders available with coolant port  
(ie: Add CP to end of description)

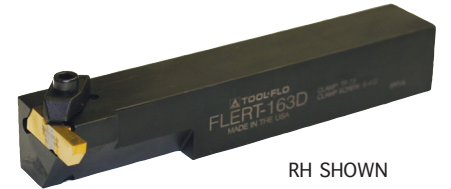
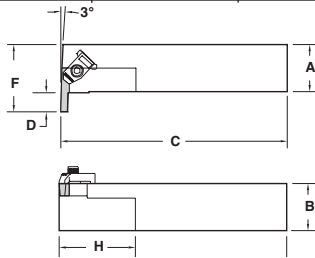

Description	EDP Code	Insert	A	B	C	D	F	Clamp	Clamp Screw
FLERT-163D	93111616D	FLGT-3L	1.000	1.000	6.000	.440	1.582	TF-72	S-412
FLELT-163D	93011616D	FLGT-3R	1.000	1.000	6.000	.440	1.582	TF-73	S-412
FLERT-203D	93112016D	FLGT-3L	1.250	1.250	6.000	.440	1.832	TF-72	S-412
FLELT-203D	93012016D	FLGT-3R	1.250	1.250	6.000	.440	1.832	TF-73	S-412
FLERT-164D	93111620D	FLGT-4L	1.000	1.000	6.000	.560	1.582	TF-72	S-412
FLELT-164D	93011620D	FLGT-4R	1.000	1.000	6.000	.560	1.582	TF-73	S-412
FLERT-204D	93112020D	FLGT-4L	1.250	1.250	6.000	.560	1.832	TF-72	S-412
FLELT-204D	93012020D	FLGT-4R	1.250	1.250	6.000	.560	1.832	TF-73	S-412

# INTERNAL BAR

## A\_FLERLT

For double ended FLGT/FLRT inserts  
Inch

*Exclusive TOOL-FLO design!*

Most holders available with coolant port  
(ie: Add CP to end of description)

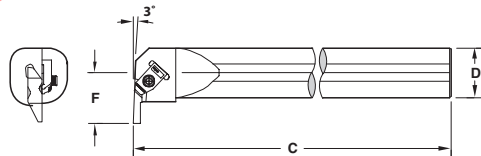

Description	EDP Code	Insert	D	C	F	Min. Bore	Clamp	Clamp Screw
A20-FLERT3	96552016	FLGT/RT-3L	1.250	6.000	1.082	1.807	TF-72	S-412
A20-FLELT3	96452016	FLGT/RT-3R	1.250	6.000	1.082	1.807	TF-73	S-412
A24-FLERT3	96552416	FLGT/RT-3L	1.500	6.000	1.207	2.057	TF-72	S-412
A24-FLELT3	96452416	FLGT/RT-3R	1.500	6.000	1.207	2.057	TF-73	S-412
A28-FLERT4	96552820	FLGT/RT-4L	1.750	6.000	1.500	2.475	TF-72	S-412
A28-FLELT4	96452820	FLGT/RT-4R	1.750	6.000	1.500	2.475	TF-73	S-412

## METRIC

Description	EDP Code	Insert	D	C	F	Min. Bore	Clamp	Clamp Screw
A32M-FLERT3	96442016	FLGT/RT-3L	32,0	152,4	27,48	46,0	TF-72	S-412
A32M-FLELT3	96432016	FLGT/RT-3R	32,0	152,4	27,48	46,0	TF-73	S-412
A40M-FLERT3	96442416	FLGT/RT-3L	40,0	152,4	31,60	54,15	TF-72	S-412
A40M-FLELT3	96432416	FLGT/RT-3R	40,0	152,4	31,60	54,15	TF-73	S-412
A50M-FLERT4	96442820	FLGT/RT-4L	50,0	152,4	40,87	68,43	TF-72	S-412
A50M-FLELT4	96432820	FLGT/RT-4R	50,0	152,4	40,87	68,43	TF-73	S-412



# FLO-LOCK

## INTERCHANGEABLE HEADS

### H-FLER

#### Threading and Grooving

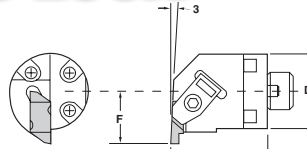

RH SHOWN

#### PARTS

Description	EDP Code	Insert	D	C	c	F	Min. Bore	Clamp	Clamp Screw
H20-FLER3W	93502016W	FL-3L	1-1/4	1.625		.875	1.750	TF-73	S-412
H24-FLER3W	93502416W	FL-3L	1-1/2	1.625		1.000	2.000	TF-73	S-412
H28-FLER3W	93502816W	FL-3L	1-3/4	1.625		1.125	2.250	TF-73	S-412
H32-FLER3W	93503216W	FL-3L	2	1.625		1.250	2.500	TF-73	S-412
H40-FLER3W	93504016W	FL-3L	2-1/2	1.625		1.500	3.000	TF-73	S-412
H28-FLER4W	93502820W	FL-4L	1-3/4	1.625		1.250	2.500	TF-73	S-412
H32-FLER4W	93503220W	FL-4L	2	1.625		1.375	2.750	TF-73	S-412
H36-FLER4W	93503620W	FL-4L	2-1/4	1.625		1.500	3.000	TF-73	S-412
H40-FLER4W	93504020W	FL-4L	2-1/2	1.625		1.625	3.250	TF-73	S-412
H28-FLER6W	93502828W	FL-6L	1-3/4	1.625		1.250	2.500	TF-121	S-412
H32-FLER6W	93503228W	FL-6L	2	1.625		1.375	2.750	TF-121	S-412
H40-FLER6W	93504028W	FL-6L	2-1/2	1.625		1.625	3.250	TF-121	S-412

\*Left hand quoted on request

### HS-FLEL/R\*

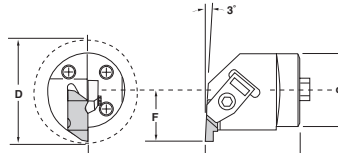

RH SHOWN

#### PARTS

Description	EDP Code	Insert	d	C	c	F	Min. Bore (D)	Clamp	Clamp Screw
HS32-FLER3W	9IHS65032M16	FL-3L	1.25	1.34		0.866	1.730	TF-73	S-412
HS40-FLER3W	9IHS65040M16	FL-3L	1.57	1.58		1.102	2.210	TF-73	S-412
HS50-FLER3W	9IHS65050M16	FL-3L	1.97	1.65		1.380	2.760	TF-73	S-412
HS60-FLER3W	9IHS65060M16	FL-3L	2.36	1.75		1.740	3.480	TF-73	S-412
HS50-FLER4W	9IHS65050M20	FL-4L	1.97	1.65		1.380	2.760	TF-73	S-412
HS60-FLER4W	9IHS65060M20	FL-4L	2.36	1.75		1.740	3.480	TF-73	S-412

\*Left hand quoted on request.

## American Standard Buttress Thread Designations

- When only the designation BUTT is used, the thread is a "pull" type buttress (external thread pulls) with the clearance flank (45°) leading and the pressure flank (7°) following.
- When the designation PUSH-BUTT is used, the thread is a push type buttress (external thread pushes) with the load flank (7°) leading and the 45° clearance flank following.
- Whenever possible this description should be confirmed by a simplified view showing thread angles on the drawing of the product that has the buttress thread.
- Always remember that the position of your holder and direction of your feed will determine the lead angle on the insert.

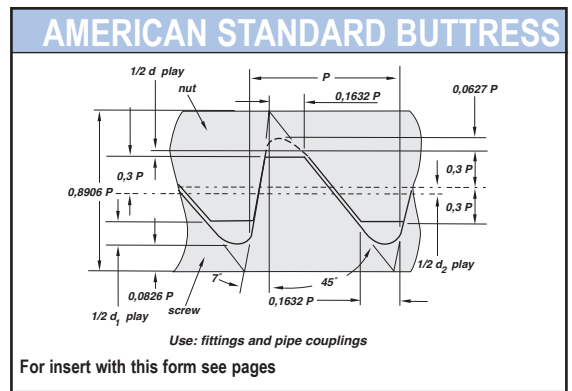
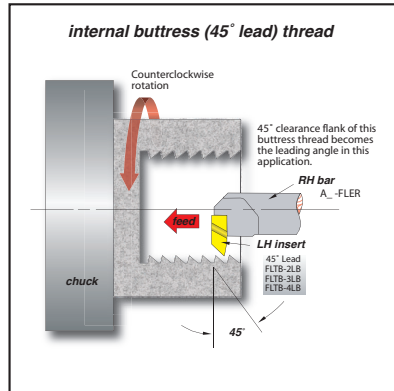
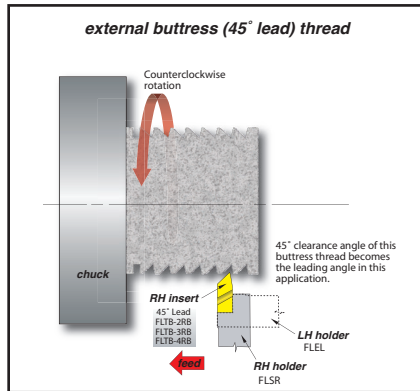

### Feed direction towards the chuck

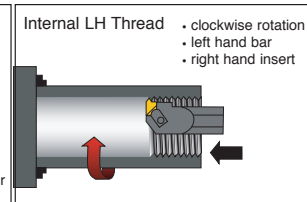
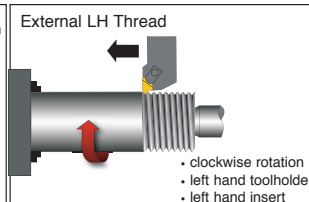
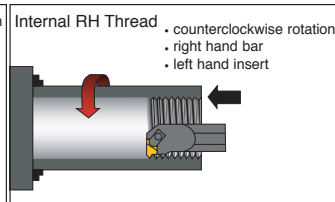
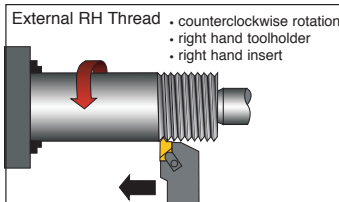

### Feed direction towards the tailstock

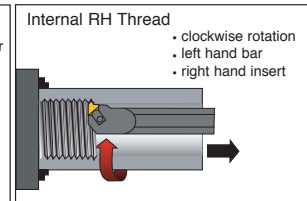
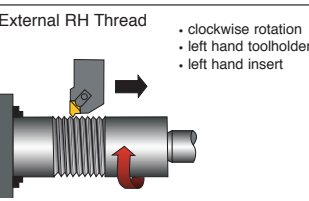
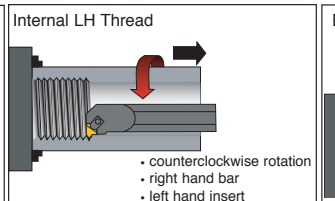
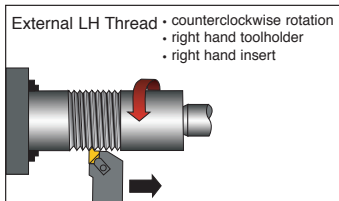

FLO-LOCK



## Threading Limits with Standard Flo-Lock Inserts

The following charts list the largest pitch that can be applied on internal applications for Acme and V-Threading Flo-Lock inserts in sizes 2,3, 4 and 6. For Buttress threads, please see previous page.

### 60° V-Threading Limits

FLT-2 Inserts internal threading limitations		
threads per inch	nominal thread size	minimum minor diameter
6	1-7/8	1.695
7	1-3/4	1.595
8	1-5/8	1.490
9	1-9/16	1.442
10	1-1/2	1.392
11	1-7/16	1.339
12	1-3/8	1.285
13	1-5/16	1.229
14	1-1/4	1.173
16	1-1/4	1.182
18	1-1/8	1.065
20	1-1/8	1.071
24	1-1/16	1.017

\* 24 TPI and finer can be cut with a #2 series insert provided that the minor diameter is 1.000 or larger.

### Acme Threading Limits

FLA-2 internal threading limitations		
threads per inch	nominal thread size	minimum minor diameter
6	2-1/2	2.333
8	2-1/4	2.125
10	2	1.900
12	1-3/4	1.667
14	1-5/8	1.554
16*	1-1/2	1.438

\*16 pitch acme threads and finer can be cut provided the minor diameter is 1.438 or larger.

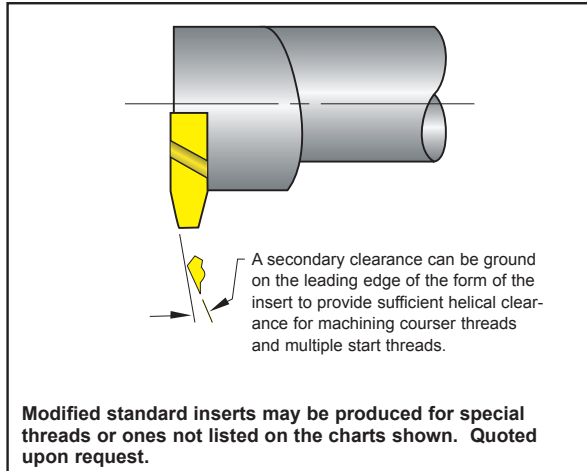

FLO-LOCK

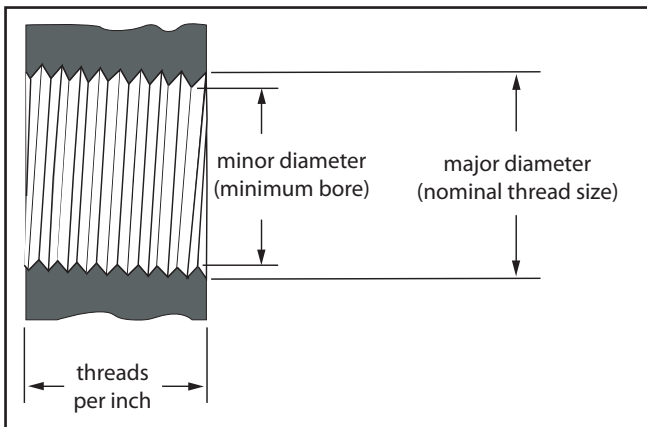

FLA-3, 4 & 6 internal threading limitations		
threads per inch	nominal thread size	minimum minor diameter
2**	5	4.500
2-1/2**	4-1/2	4.100
3**	4	3.665
4	3-1/2	3.250
5	3	2.800
6	2-1/2	2.333
8	2-1/4	2.125
10	2	1.900
12	1-3/4	1.667
14	1-5/8	1.554
16*	1-1/2	1.438

\*16 pitch acme threads and finer can be cut provided the minor diameter is 1.438 or larger. \*\*FLA-6 only.

NOTE: Positive rake acme inserts are recommended for stainless steels and high-temp alloy applications. Quoted upon request.

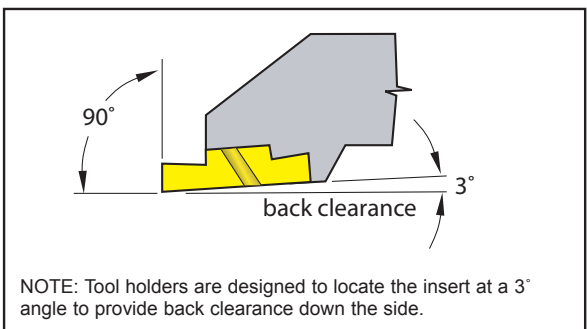

FLT-3 & 4 Inserts internal threading limitations		
threads per inch	nominal thread size	minimum minor diameter
4**	3	2.729
4-1/2**	2-7/8	2.634
5	2-3/4	2.534
6	2-1/2	2.320
7	2-1/4	2.095
8	2	1.865
9	1-15/16	1.817
10	1-7/8	1.767
11	1-13/16	1.714
12	1-3/4	1.660
13	1-5/8	1.542
14	1-9/16	1.485
16*	1-7/16	1.370

\*16 pitch V threads and finer can be cut provided the minor diameter is 1.370 or larger. \*\*FLT-4 only.

FLT-2A & 2B internal threading limitations		
threads per inch	nominal thread size	minimum minor diameter
8	1-3/4	1.600
10	1-5/8	1.505
12	1-1/2	1.400
16	1-1/4	1.175
20	1-1/16	1.002

FLT-3A & 4A internal threading limitations		
threads per inch	nominal thread size	minimum minor diameter
4*	2-1/2	2.200
5	2-1/4	2.010
6	2	1.800
8	1-3/4	1.600
10	1-5/8	1.505
12**	1-1/2	1.400

\* FLT-4A insert only  
\*\* Sixteen or 20 threads per inch can be cut providing minor diameter is 1.375 or larger.

FLT-3B & 4B internal threading limitations		
threads per inch	nominal thread size	minimum minor diameter
4	*2-7/8	2.575
5	2-3/4	2.510
6	2-3/8	1.175
8	2-1/8	1.975
10	1-7/8	1.755
12	1-5/8	1.525
16	1-1/2	1.407
20	1-7/16	1.378

\* FLT-4B insert only